



**X S T A C K**<sup>®</sup>

# Hardware Installation Guide

Product Model: xStack<sup>®</sup> DGS-3600 Series

Layer 3 Managed Gigabit Ethernet Switch

Release 2.8



Information in this document is subject to change without notice.

© 2010 D-Link Corporation. All rights reserved.

Reproduction in any manner whatsoever without the written permission of D-Link Corporation is strictly forbidden.

Trademarks used in this text: D-Link and the D-LINK logo are trademarks of D-Link Corporation; Microsoft and Windows are registered trademarks of Microsoft Corporation.

Other trademarks and trade names may be used in this document to refer to either the entities claiming the marks and names or their products. D-Link Corporation disclaims any proprietary interest in trademarks and trade names other than its own.

August 2010 P/N 651GS3600055G

**FCC Warning**

This equipment has been tested and found to comply with the limits for a Class A digital device, pursuant to Part 15 of the FCC Rules. These limits are designed to provide reasonable protection against harmful interference when the equipment is operated in a commercial environment. This equipment generates, uses, and can radiate radio frequency energy and, if not installed and used in accordance with this manual, may cause harmful interference to radio communications. Operation of this equipment in a residential area is likely to cause harmful interference in which case the user will be required to correct the interference at their expense.

**CE Mark Warning**

This is a Class A product. In a domestic environment, this product may cause radio interference in which case the user may be required to take adequate measures.

**Warnung!**

Dies ist ein Produkt der Klasse A. Im Wohnbereich kann dieses Produkt Funkstörungen verursachen. In diesem Fall kann vom Benutzer verlangt werden, angemessene Massnahmen zu ergreifen.

**Precaución!**

Este es un producto de Clase A. En un entorno doméstico, puede causar interferencias de radio, en cuyo caso, puede requerirse al usuario para que adopte las medidas adecuadas.

**Attention!**

Ceci est un produit de classe A. Dans un environnement domestique, ce produit pourrait causer des interférences radio, auquel cas l'utilisateur devrait prendre les mesures adéquates.

**Attenzione!**

Il presente prodotto appartiene alla classe A. Se utilizzato in ambiente domestico il prodotto può causare interferenze radio, nel cui caso è possibile che l'utente debba assumere provvedimenti adeguati.

**VCCI Warning**

この装置は、クラス A 情報技術装置です。この装置を家庭環境で使用すると電波妨害を引き起こすことがあります。この場合には使用者が適切な対策を講ずるよう要求されることがあります。

VCCI-A

# Table of Contents

---

Intended Readers .....	vi
Typographical Conventions .....	vi
Notes, Notices, and Cautions .....	vi
Safety Instructions.....	vii
Safety Cautions .....	vii
General Precautions for Rack-Mountable Products .....	viii
Lithium Battery Precaution.....	ix
Protecting Against Electrostatic Discharge.....	ix
<b>Introduction.....</b>	<b>1</b>
Features .....	2
Ports .....	5
Front Panel Components .....	6
LEDs .....	7
Rear Panel .....	9
Side Panel.....	10
<b>Installation.....</b>	<b>11</b>
Package Contents .....	11
Installation Guidelines .....	11
Installing the Switch without the Rack.....	12
Installing the Switch in a Rack.....	12
Mounting the Switch in a Standard 19" Rack .....	13
Power On .....	13
Power Failure .....	13
Installing the SFP Ports.....	14
Optional 10GE Uplink Module .....	14
External Redundant Power System.....	16
Connect to RPS .....	17
DPS-200.....	18
DPS-900.....	18
DPS-800.....	19
<b>Connecting the Switch .....</b>	<b>20</b>
Switch to End Node .....	20
Switch to Hub or Switch .....	21
Connecting to Network Backbone or Server.....	21
<b>Introduction to Switch Management .....</b>	<b>22</b>
Management Options .....	22
Connecting the Console Port (RS-232 DCE).....	22
Managing the Switch for the First Time .....	24
Password Protection.....	25
SNMP Settings.....	26

Traps .....	26
MIBs .....	26
IP Address Assignment .....	26
<b>Web-based Switch Configuration.....</b>	<b>29</b>
Introduction.....	29
Logging in to the Web Manager .....	30
Web-based User Interface .....	31
Areas of the User Interface .....	31
Web Pages.....	32
<b>Technical Specifications .....</b>	<b>33</b>
<b>Cables and Connectors .....</b>	<b>36</b>
<b>Cable Lengths.....</b>	<b>37</b>
<b>Glossary .....</b>	<b>38</b>
<b>Warranties and Tech Support Information .....</b>	<b>40</b>

## Intended Readers

The *xStack® DGS-3600 Series Hardware Installation Guide* contains information for setup and management of the Switch. This manual is intended for network managers familiar with network management concepts and terminology.

## Typographical Conventions

Convention	Description
[ ]	In a command line, square brackets indicate an optional entry. For example: [copy filename] means that optionally you can type copy followed by the name of the file. Do not type the brackets.
<b>Bold font</b>	Indicates a button, a toolbar icon, menu, or menu item. For example: Open the <b>File</b> menu and choose <b>Cancel</b> . Used for emphasis. May also indicate system messages or prompts appearing on screen. For example: <b>You have mail</b> . <b>Bold</b> font is also used to represent filenames, program names and commands. For example: <b>use the copy command</b> .
<b>Boldface Typewriter Font</b>	Indicates commands and responses to prompts that must be typed exactly as printed in the manual.
Initial capital letter	Indicates a window name. Names of keys on the keyboard have initial capitals. For example: Click Enter.
<i>Italics</i>	Indicates a window name or a field. Also can indicate a variables or parameter that is replaced with an appropriate word or string. For example: type <i>filename</i> means that the actual filename should be typed instead of the word shown in italic.
<b>Menu Name &gt; Menu Option</b>	<b>Menu Name &gt; Menu Option</b> Indicates the menu structure. <b>Device &gt; Port &gt; Port Properties</b> means the Port Properties menu option under the Port menu option that is located under the Device menu.

## Notes, Notices, and Cautions



A **NOTE** indicates important information that helps make better use of the device.



A **NOTICE** indicates either potential damage to hardware or loss of data and tells how to avoid the problem.



A **CAUTION** indicates a potential for property damage, personal injury, or death.

# Safety Instructions

Use the following safety guidelines to ensure your own personal safety and to help protect your system from potential damage.

Throughout this safety section, the caution icon (  ) is used to indicate cautions and precautions that need to be reviewed and followed.



## Safety Cautions

To reduce the risk of bodily injury, electrical shock, fire, and damage to the equipment observe the following precautions:

- Observe and follow service markings.
  - Do not service any product except as explained in the system documentation.
  - Opening or removing covers that are marked with the triangular symbol with a lightning bolt may expose the user to electrical shock.
  - Only a trained service technician should service components inside these compartments.
- If any of the following conditions occur, unplug the product from the electrical outlet and replace the part or contact your trained service provider:
  - Damage to the power cable, extension cable, or plug.
  - An object has fallen into the product.
  - The product has been exposed to water.
  - The product has been dropped or damaged.
  - The product does not operate correctly when the operating instructions are correctly followed.
- Keep your system away from radiators and heat sources. Also, do not block cooling vents.
- Do not spill food or liquids on system components, and never operate the product in a wet environment. If the system gets wet, see the appropriate section in the troubleshooting guide or contact your trained service provider.
- Do not push any objects into the openings of the system. Doing so can cause fire or electric shock by shorting out interior components.
- Use the product only with approved equipment.
- Allow the product to cool before removing covers or touching internal components.
- Operate the product only from the type of external power source indicated on the electrical ratings label. If unsure of the type of power source required, consult your service provider or local power company.
- To help avoid damaging the system, be sure the voltage selection switch (if provided) on the power supply is set to match the power available at the Switch's location:
  - 115 volts (V)/60 hertz (Hz) in most of North and South America and some Far Eastern countries such as South Korea and Taiwan
  - 100 V/50 Hz in eastern Japan and 100 V/60 Hz in western Japan
  - 230 V/50 Hz in most of Europe, the Middle East, and the Far East
- Also, be sure that attached devices are electrically rated to operate with the power available in your location.
- Use only approved power cable(s). If you have not been provided with a power cable for your system or for any AC-powered option intended for your system, purchase a power cable that is approved for use in your country. The power cable must be rated for the product and for the voltage and current marked on the product's electrical ratings label. The voltage and current rating of the cable should be greater than the ratings marked on the product.

- To help prevent electric shock, plug the system and peripheral power cables into properly grounded electrical outlets. These cables are equipped with three-prong plugs to help ensure proper grounding. Do not use adapter plugs or remove the grounding prong from a cable. If using an extension cable is necessary, use a 3-wire cable with properly grounded plugs.
- Observe extension cable and power strip ratings. Make sure that the total ampere rating of all products plugged into the extension cable or power strip does not exceed 80 percent of the ampere ratings limit for the extension cable or power strip.
- To help protect the system from sudden, transient increases and decreases in electrical power, use a surge suppressor, line conditioner, or uninterruptible power supply (UPS).
- Position system cables and power cables carefully; route cables so that they cannot be stepped on or tripped over. Be sure that nothing rests on any cables.
- Do not modify power cables or plugs. Consult a licensed electrician or your power company for site modifications. Always follow your local/national wiring rules.
- When connecting or disconnecting power to hot-pluggable power supplies, if offered with your system, observe the following guidelines:
  - Install the power supply before connecting the power cable to the power supply.
  - Unplug the power cable before removing the power supply.
  - If the system has multiple sources of power, disconnect power from the system by unplugging all power cables from the power supplies.
- Move products with care; ensure that all casters and/or stabilizers are firmly connected to the system. Avoid sudden stops and uneven surfaces.



## General Precautions for Rack-Mountable Products

Observe the following precautions for rack stability and safety. Also, refer to the rack installation documentation accompanying the system and the rack for specific caution statements and procedures.

- Systems are considered to be components in a rack. Thus, "component" refers to any system as well as to various peripherals or supporting hardware.



**CAUTION:** Installing systems in a rack without the front and side stabilizers installed could cause the rack to tip over, potentially resulting in bodily injury under certain circumstances. Therefore, always install the stabilizers before installing components in the rack. After installing system/components in a rack, never pull more than one component out of the rack on its slide assemblies at one time. The weight of more than one extended component could cause the rack to tip over and may result in serious injury.

- Before working on the rack, make sure that the stabilizers are secured to the rack, extended to the floor, and that the full weight of the rack rests on the floor. Install front and side stabilizers on a single rack or front stabilizers for joined multiple racks before working on the rack.
- Always load the rack from the bottom up, and load the heaviest item in the rack first.
- Make sure that the rack is level and stable before extending a component from the rack.
- Use caution when pressing the component rail release latches and sliding a component into or out of a rack; the slide rails can pinch your fingers.
- After a component is inserted into the rack, carefully extend the rail into a locking position, and then slide the component into the rack.
- Do not overload the AC supply branch circuit that provides power to the rack. The total rack load should not exceed 80 percent of the branch circuit rating.
- Ensure that proper airflow is provided to components in the rack.



- Do not step on or stand on any component when servicing other components in a rack.



**NOTE:** A qualified electrician must perform all connections to DC power and to safety grounds. All electrical wiring must comply with applicable local or national codes and practices.



**CAUTION:** Never defeat the ground conductor or operate the equipment in the absence of a suitably installed ground conductor. Contact the appropriate electrical inspection authority or an electrician if uncertain that suitable grounding is available.



**CAUTION:** The system chassis must be positively grounded to the rack cabinet frame. Do not attempt to connect power to the system until grounding cables are connected. Completed power and safety ground wiring must be inspected by a qualified electrical inspector. An energy hazard will exist if the safety ground cable is omitted or disconnected.

## Lithium Battery Precaution



**CAUTION:** Incorrectly replacing the lithium battery of the Switch may cause the battery to explode. Replace this battery only with the same or equivalent type recommended by the manufacturer. Discard used batteries according to the manufacturer instructions.

## Protecting Against Electrostatic Discharge

Static electricity can harm delicate components inside the system. To prevent static damage, discharge static electricity from your body before touching any of the electronic components, such as the microprocessor. This can be done by periodically touching an unpainted metal surface on the chassis.

The following steps can also be taken prevent damage from electrostatic discharge (ESD):

1. When unpacking a static-sensitive component from its shipping carton, do not remove the component from the antistatic packing material until ready to install the component in the system. Just before unwrapping the antistatic packaging, be sure to discharge static electricity from your body.
2. When transporting a sensitive component, first place it in an antistatic container or packaging.
3. Handle all sensitive components in a static-safe area. If possible, use antistatic floor pads, workbench pads and an antistatic grounding strap.

# Introduction

## ***Front Panel Components***

### ***LED Indicators***

### ***Rear Panel***

### ***Side Panel***

The DGS-3600 Gigabit Ethernet switches are members of the D-Link xStack® family. Ranging from 10/100Mbps edge switches to core gigabit switches, the xStack® switch family has been designed to deliver a system with fault tolerance, flexibility, port density, robust security, and maximum throughput, with a user-friendly management interface for the networking professional.

This manual describes the installation, maintenance and configurations concerning members of the xStack® DGS-3600 Series. These switches include: the DGS-3612, DGS-3612G, DGS-3627, DGS-3627G, and the DGS-3650. The xStack® DGS-3600 switches are similar in configurations and basic hardware and consequentially, most of the information in this manual will be universal to the whole xStack® DGS-3600 Series. Corresponding screen pictures of the Web manager may be taken from any one of these switches but the configuration will be identical, except for varying port counts.

The switches are equipped with unshielded twisted-pair (UTP) cable ports providing dedicated 10, 100 or 1000 Mbps bandwidth. The DGS-3627 is equipped with twenty-four 10/100/1000BASE-T ports, and the DGS-3650 has forty-eight 10/100/1000BASE-T ports, all of which are Auto MDI-X/MDI-II convertible ports that can be used for uplinking to another switch. The DGS-3612G is equipped with twelve 100/1000Mbps SFP (Small Form Factor Portable) ports, in addition to four 1000BASE-T located on the front panel. These ports can be used for connecting PCs, printers, servers, hubs, routers, switches and other networking devices. The dual speed ports use standard twisted-pair cabling and are ideal for segmenting networks into small, connected sub networks for superior performance. Each 10/100/1000 port can support up to 2000 Mbps of throughput in full-duplex mode. In addition, the Switch has four 1000Mbps SFP combo ports located on the front panel. These gigabit combo ports are ideal for connecting to a server or network backbone.

The DGS-3627G contains twenty-four 1000Mbps SFP (Small Form Factor Portable) ports, in addition to four 1000BASE-T located on the front panel. The DGS-3612 contains twelve 10/100/1000BASE-T ports, all of which are Auto MDI-X/MDI-II convertible ports that can be used for uplinking to another switch, and four 100/1000Mbps SFP (Small Form Factor Portable) ports. The SFP combo ports are to be used with fiber-optical transceiver cabling in order to uplink various other networking devices for a gigabit link that may span great distances. The SFP ports can also support full-duplex transmissions, have auto-negotiation and can be used with DEM-210 (100FX-LC), DEM-211 (100FX-LC), DEM-310GT (1000BASE-LX), DEM-311GT (1000BASE-SX), DEM-312GT2 (1000BASE-SX), DEM-314GT (1000BASE-LH), DEM-315GT (1000BASE-ZX), DEM-330T/R (WDM Transceiver) and the DEM-331T/R (WDM Transceiver) transceivers. These ports are referred to as “combo” ports. That means both the SFP ports and the 1000BASE-T ports are numbered the same and cannot be used simultaneously. Attempting to use the ports simultaneously will cause a link down status for the 1000BASE-T ports. SFP ports will always have priority over these 1000BASE-T ports.

The DGS-3627, DGS-3627G, and DGS-3650 contain open slots in the back of the switches that are used to add optional single-port 10GE modules. Two available slots reside within the DGS-3650, while the DGS-3627 and DGS-3627G both contain three slots. These modules, the DEM-410CX CX4 and the DEM-410X XFP, are IEEE 802.3ae and IEEE 802.3ak compliant and support full-duplex mode only. More information will be provided on these modules later in this manual.

The DGS-3600 Switch Series enables a network to use some of the most demanding multimedia and imaging applications concurrently with other user applications without creating bottlenecks. The built-in console interface can be used to configure the Switch's settings for priority queuing, VLANs, port trunk groups, port monitoring, and port speed.

## Features

The list of features and protocols below highlights the significant features supported by the xStack® DGS-3600 Series.

- Physical Stacking—up to 12 devices, with a bandwidth up to 40G
- Virtual Stacking
- IEEE 802.3ad Link Aggregation Control Protocol
- IEEE 802.1X Port-based and MAC-based Access Control
- IEEE 802.1Q VLAN
- IEEE 802.1D Spanning Tree, IEEE 802.1w Rapid Spanning Tree, and IEEE 802.1s Multiple Spanning Tree
- IEEE 802.3x flow control in full duplex mode
- IEEE 802.1p Priority Queues
- IEEE 802.3u 100BASE-TX
- Access Control List (ACL)
- Single IP Management
- Access Authentication Control (AAC) utilizing TACACS, XTACACS, and TACACS+
- Internal Flash Drive for saving configurations and firmware
- Simple Network Time Protocol (SNTP)
- MAC Notification
- VLAN Group—maximum 4K static VLAN groups, maximum 255 dynamic VLAN groups
- Configurable VLAN ID—1 to 4094
- Double VLAN
- Q-in-Q—translation VLAN ASIC 768 entries
- Guest VLAN
- IGMP Snooping Multicast VLAN (ISM VLAN), including tag/untagged member and source support and configurable multicast VLAN priority—there is no limit on the total multicast address number per ISM VLAN entry
- MAC-based VLAN—ASIC 1024 VLAN MAC entries
- VLAN PVID auto assign
- VLAN trunking
- Subnet VLAN
- Super VLAN
- BPDU Protection
- ITU-T G.8032 Ethernet Ring Protection Switching (ERPS)—support for 2 rings
- System and Port Utilization
- 8-level System Log
- Port-based enable and disable
- Address table: up to 16K MAC addresses per device
- Packet buffer of up to 2M bytes
- Port Trunking with flexible load distribution and fail-over function
- Link Aggregation Control Protocol (LACP) supports load-balancing with multicast traffic
- IGMP Snooping
- MLD Snooping
- SNMP
- Telnet Client
- TFTP Client
- RMONv1/v2
- CPU Monitoring
- Remote Switched Port Analyzer (RSPAN)
- Link Layer Discovery Protocol (LLDP)
- Layer 2 Protocol tunneling
- Secure Sockets Layer (SSL) v3 and Secure Shell (SSH) v2
- Port Security

- Port Mirroring, including multiple session support and ability for link aggregation to be set as target port
- Network Load Balancing (NLB), a MAC forwarding control for supporting the Microsoft server load balancing application where multiple servers can share the same IP address and MAC address
- Per port queue egress bandwidth control
- Cable diagnostics
- sFlow, including support for IPv6 server
- D-Link Unidirectional Link Detection (DULD)--unidirectional link detection provides a mechanism that can be used to detect unidirectional links for Ethernet switches whose PHYs do not support unidirectional OAM operation
- Password Recovery v1.1
- Password Encryption
- Ping
- BIN file
- Technical Support
- Web-based Access Control (WAC)
- Japanese Web-based Access Control (JWAC)
- Compound Authentication
- ARP Spoofing Prevention
- RADIUS account
- RADIUS support for IPv6
- IP-MAC-Port Binding (IMPB) v3.5
- IP-MAC-Port Binding (IMPB) DHCPv6 security
- IP-MAC-Port Binding (IMPB) ND Snooping-based security
- IP Directed Broadcast
- Loopback interface
- IGMP Source network check enable/disable
- Multicast Route Management—IPMC L2 Forward
- Border Gateway Protocol (BGP)
- Open Shortest Path First (OSPF) v2/v3
- Open Shortest Path First (OSPF) Passive Interface
- Open Shortest Path First Not So Stubby Area (OSPF NSSA)
- 64 IP interfaces
- Multiple IP interfaces per VLAN—5 IP interfaces per VLAN with a maximum of 256 interfaces per Switch
- IP interface MTU configuration
- Multi Path Routing—support both Equal Cost (EC) and Weighted Cost (WC)
- VRRP
- IPv6 Ready Phase 1
- Multicast table size—1K multicast groups shared by static and dynamic multicast groups: maximum 64 static multicast groups and maximum 1L dynamic multicast groups
- IGMP v1/v2/v3
- DVMRP v3
- PIM DM—support IPv4
- PIM SM—support IPv4
- PIM Sparse-Dense Mode
- ARP Proxy
- Gratuitous ARP with trap and log event
- Multicast duplication—hardware packet replication up to 32 VLANs per port
- Per port limit IP multicast address range—only for control packets
- Host-based IGMP Fast Leave
- Multicast static route
- Trace route support for IPv6
- IP tunneling—support RA for ISATAP tunnel, 6 to 4 tunnel, manual tunnel, and ISATAP tunnel

- Routing table size--total 12K routing entries, all IPv4/IPv6 static and dynamic routes share these entries: maximum 256 entries for IPv4 static routes, maximum 128 entries for IPv6 static routes, maximum 12K entries for IPv4 dynamic routes, maximum 6K entries for IPv6 dyanmic routes
- L3 Forwarding table size—total 8K L3 hardware forwarding entries, both IPv4 and IPv6 forwarding share these entries: maximum 8k entries for IPv4 and maximum 4K entries for IPv6
- Floating static routing—IPv4 and IPv6
- Policy-based routing
- RIP v1/v2
- RIPng (IPv6)
- DHCP Server—support 1024 entries and 8 pools
- DHCPv6 Server
- DHCPv6 Relay
- DHCPv6 Client
- DNS Client
- Remote Copy Protocol (RCP)
- BOOTP/DHCP Relay—DHCP local relay, block broadcast packets in DHCP relay, DHCP relay option 60 and 61
- Command Line Interface (CLI)
- Passed Metro Ethernet Forum (MEF) 9 and 14
- MIBs for:
  - RFC1213 MIB II
  - RFC1493 Bridge MIB
  - RFC 1907 SNMPv2 MIB
  - RFC 1757 and RFC 2819 RMON
  - RFC 2021 RMONv2
  - RFC 1643, RFC 2358, and RFC 2665 Ether-like MIB
  - RFC 2668 802.3 MAU MIB
  - RFC 2674 for 802.1p MIB
  - RFC 2233 and RFC 2863 Interface MIB
  - RFC 2618 RADIUS Authentication Client MIB
  - IGMPv3 MIB
  - RFC 1724 RIPv2 MIB
  - RFC 1850 OSPFv2 MIB
  - RFC 2096 IP Forwarding Table MIB (CIDR)
  - RFC 2787 VRRP MIB
  - RFC 2932 IPv4 Multicasting Routing MIB
  - RFC 2934 PIM MIB for IPv4
  - RFC 2620 RADIUS Accounting Client MIB
  - L2 Specific MIB
  - L3 Specific MIB
  - Private MIB
  - Entity MIB
  - Show MemoryUsage/Percentage MIB
- An RS-232 DCE console port for Switch management
- Parallel LED display for port status such as link/act, speed, etc.
- IEEE 802.3 10BASE-T
- Non-blocking store and forward switching scheme capability to support rate adaptation and protocol conversion
- By-port Egress/Ingress rate control.
- Efficient self-learning and address recognition mechanism enables forwarding rate at wire speed

## Ports

The following table lists the relative ports that are present within each switch:

DGS-3612	DGS-3612G	DGS-3627	DGS-3627G	DGS-3650
<p>Twelve 10/100/1000BASE-T Ports</p> <p>Four SFP Combo Ports</p> <p>One female DCE RS-232 DB-9 console port</p>	<p>Twelve 100/1000Mbps SFP Ports</p> <p>Four 1000BASE-T Combo Ports</p> <p>One female DCE RS-232 DB-9 console port</p>	<p>Twenty-four 10/100/1000BASE-T</p> <p>Four SFP Combo Ports</p> <p>Three open slots used to add single-port 10GE modules</p> <p>One female DCE RS-232 DB-9 console port</p>	<p>Twenty-four 1000Mbps SFP Ports</p> <p>Four 1000BASE-T Combo Ports</p> <p>Three open slots used to add single-port 10GE modules</p> <p>One female DCE RS-232 DB-9 console port</p>	<p>Forty-eight 10/100/1000BASE-T</p> <p>Four SFP Combo Ports</p> <p>Two open slots used to add single-port 10GE modules</p> <p>One female DCE RS-232 DB-9 console port</p>

The following table lists the features and compatibility for each type of port present in the xStack® DGS-3600 Series.

10/100/1000BASE-T	SFP Combo	1000BASE-T Combo	10GE Module
<p>IEEE 802.3 compliant</p> <p>IEEE 802.3u compliant</p> <p>IEEE 802.3x flow control support in full-duplex</p> <p>One connector in the rear to add an external Redundant Power Supply (DPS-500)*</p> <p>Auto MDI-X/MDI-II cross over support</p> <p>*DGS-3612 uses a DPS-200 Redundant Power Supply</p>	<p>Supports the following SFP transceivers:</p> <p>DEM-310GT (1000BASE-LX)</p> <p>DEM-311GT (1000BASE-SX)</p> <p>DEM-312GT2 (1000BASE-LX)</p> <p>DEM-314GT (1000BASE-LH)</p> <p>DEM-315GT (1000BASE-ZX)</p> <p>DEM-330T/R (WDM)</p> <p>DEM-331T/R (WDM)</p> <p>DEM-210* (100FX_LC SM 15Km)</p> <p>DEM-211* (100FX_LC MM 2Km)</p> <p>Takes priority over its 10/100/1000BASE-T combo ports</p> <p>IEEE 802.3z compliant</p> <p>*DGS-3612 &amp; DGS-3612G only</p>	<p>IEEE 802.3 compliant</p> <p>IEEE 802.3u compliant</p> <p>IEEE 802.3ab compliant</p> <p>IEEE 802.3z compliant</p> <p>IEEE 802.3x flow control support in full-duplex</p>	<p>IEEE 802.3ae compliant</p> <p>IEEE 802.3ak compliant</p> <p>Full-duplex only</p> <p>Supports the following modules:</p> <p>DEM-410CX Single-Port CX4</p> <p>DEM-410X Single-Port XFP</p> <p>One connector in the rear to add an external Redundant Power Supply (DPS-500)</p>



**NOTE:** The SFP combo ports on the Switch cannot be used simultaneously with the corresponding 1000BASE-T ports. If both ports are in use at the same time (ex. port 1 of the SFP and port 1 of the 1000BASE-T), the SFP ports will take priority over the combo ports and render the 1000BASE-T ports inoperable.

# Front Panel Components

## DGS-3612

- Twelve 10/100/1000BASE-T ports
- Four Combo SFP ports located to the right
- One female DCE RS -232 DB-9 console port
- LEDs for Power, Console, RPS, and Link/Act/Speed for each port

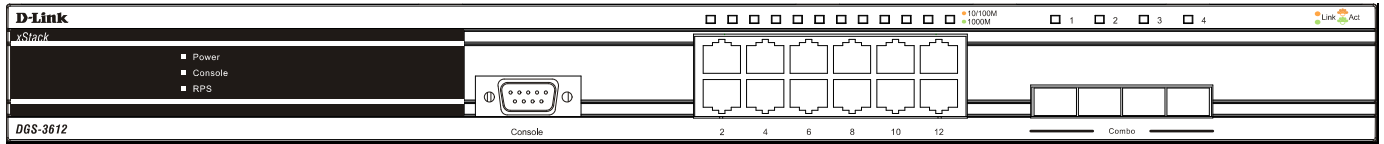

Figure 1- 1. Front Panel of the DGS-3612

## DGS-3612G

- Twelve SFP 100/1000Mbps ports
- Four Combo 1000BASE-T ports located to the right
- One female DCE RS -232 DB-9 console port
- LEDs for Power, Console, RPS, and Link/Act/Speed for each port

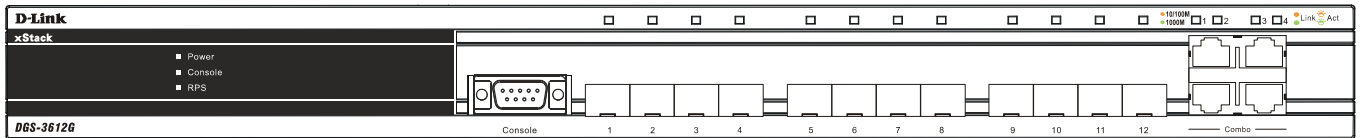

Figure 1- 2. Front Panel of the DGS-3612G

## DGS-3627

- Twenty-four 10/100/1000BASE-T ports
- Four Combo SFP ports located to the right
- One female DCE RS-232 DB-9 console port
- LEDs for Power, Console, RPS, Link/Act/Speed and 10GE for each port
- Stacking Module Numbered LED

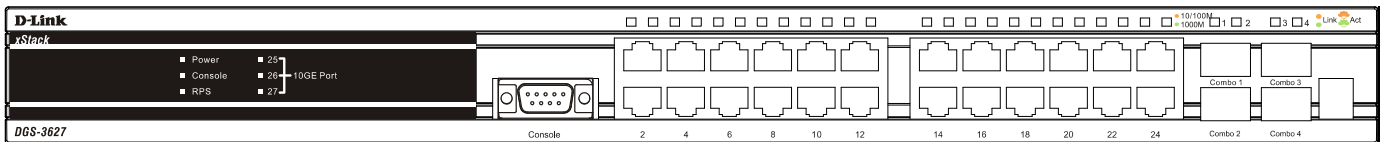

Figure 1- 3. Front Panel of the DGS-3627

## DGS-3627G

- Twenty-four SFP 1000Mbps ports
- Four Combo 1000BASE-T ports located to the right
- One female DCE RS -232 DB-9 console port
- LEDs for Power, Console, RPS, Link/Act/Speed and 10GE for each port
- Stacking Module Numbered LED

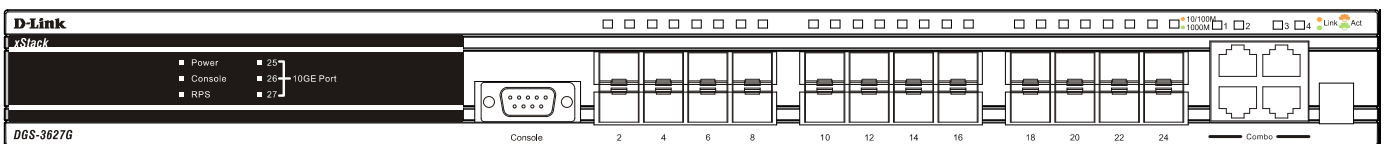

Figure 1- 4. Front Panel of the DGS-3627G

### DGS-3650

- Forty-eight 10/100/1000BASE-T ports
- Four Combo SFP ports located to the right
- One female DCE RS -232 DB-9 console port
- LEDs for Power, Console, RPS, Link/Act/Speed and 10GE for each port
- Stacking Module Numbered LED

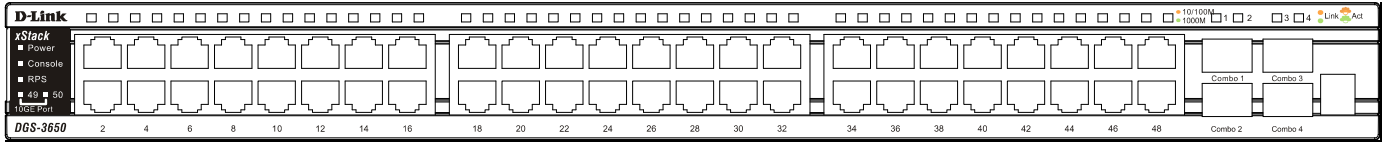

Figure 1- 5. Front Panel of the DGS-3650

## LEDs

The following table lists the LEDs located on models of the xStack® DGS-3600 Series switches along with their corresponding description:

LED Indicator	Color	Status	Description
Power	Green	Solid	Power On
		Dark	Power Off
Console	Green	Solid	Console On
		Dark	Console Off
RPS	Green	Solid	RPS in use
		Dark	RPS not in use or not present
Stacking LED	Green	Numbered 1-12	Box ID of the Switch in the switch stack. This field will read 1 for a switch in standalone mode. When the switch in question is a master of a switch stack, the number of the switch in the stack will be displayed, and the letter H will flash alternatively with this number.
Port LEDs (10/100/1000Mbps ports)	Green	Solid	Denotes an active connection at 1000Mbps.
		Blinking	Denotes data transfer at 1000Mbps.
	Orange	Solid	Denotes an active connection at 10/100Mbps.
		Blinking	Denotes data transfer at 10/100Mbps.
Dark	No Light	Link Down	
SFP Port LED	Green	Solid	Denotes an active connection at 1000Mbps.
		Blinking	Denotes data transfer at 1000Mbps.
	Orange (DGS-3612 and DGS-3612G only)	Solid	Denotes an active connection at 100Mbps.
		Blinking	Denotes data transfer at 100Mbps.
Dark	No Light	Link Down	
10GE Module LEDs (Located on the front panel)	Green	Solid	Denotes an active connection.
		Blinking	Denotes data transfer.
	Dark	No Light	Link Down



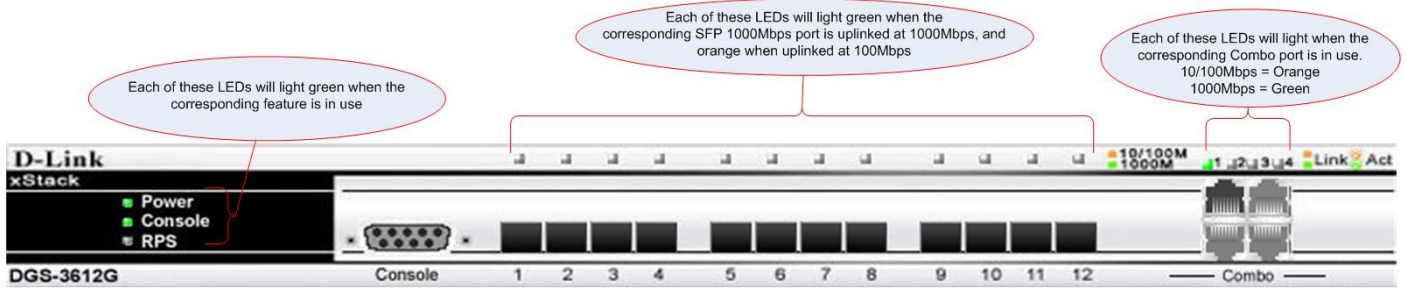

**Figure 1- 6. DGS-3612G LEDs**

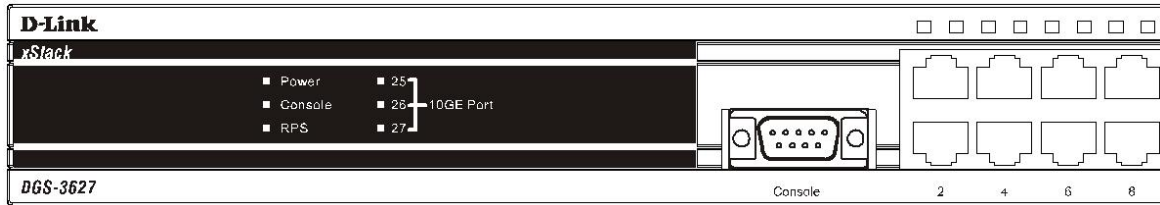

**Figure 1- 7. DGS-3627 LEDs**



**Figure 1- 8. DGS-3627G LEDs**

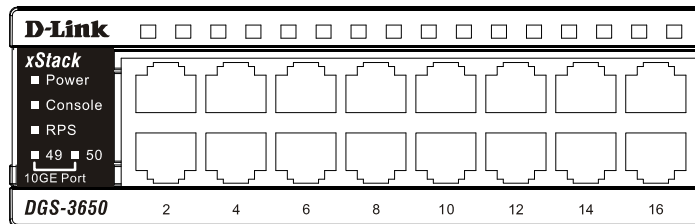

**Figure 1- 9. DGS-3650 LEDs**

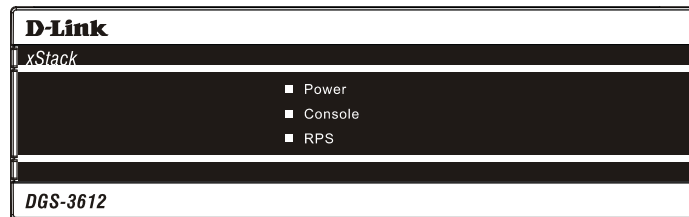

**Figure 1- 10. DGS-3612 LEDs**

## Rear Panel

The rear panels of the DGS-3612, DGS-3612G, DGS-3627, DGS-3627G and the DGS-3650 are described below.

### DGS-3612 and DGS-3612G

The rear panel of the DGS-3612 and the DGS-3612G contains an AC power connector, and an outlet for an optional external RPS.

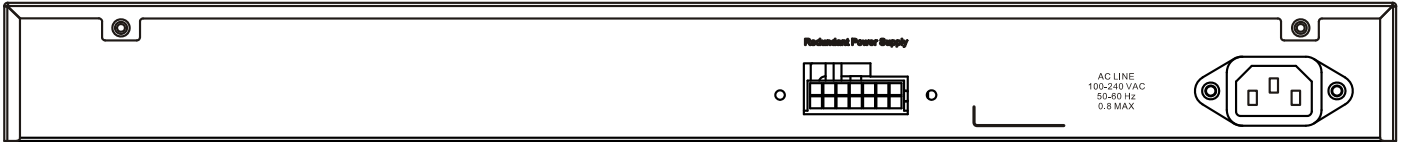

Figure 1- 11. Rear panel view of the DGS-3612

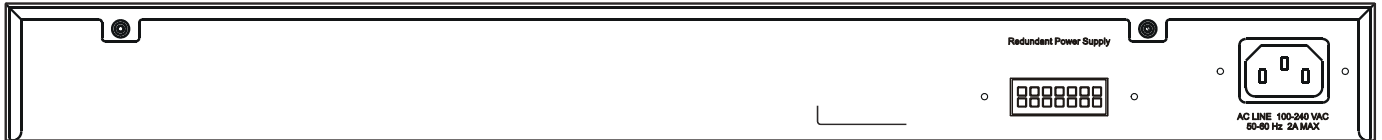

Figure 1- 12. Rear panel view of the DGS-3612G

### DGS-3627 and DGS-3627G

The rear panel of DGS-3627 and DGS-3627G contain an AC power connector, an outlet for an optional external RPS, and three slots for additional 10GE optional modules.

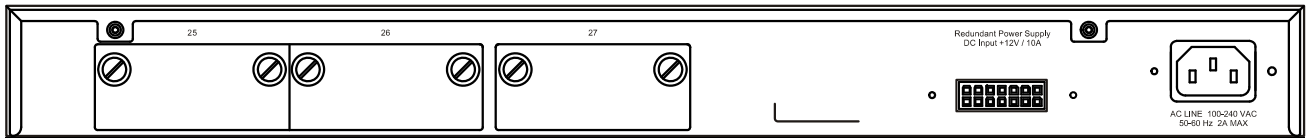

Figure 1- 13. Rear panel view of the DGS-3627 and DGS-3627G

### DGS-3650

The rear panel of DGS-3650 contains an AC power connector, an outlet for an optional external RPS, a DCE RS-232 console port, and two slots for additional 10GE optional modules.

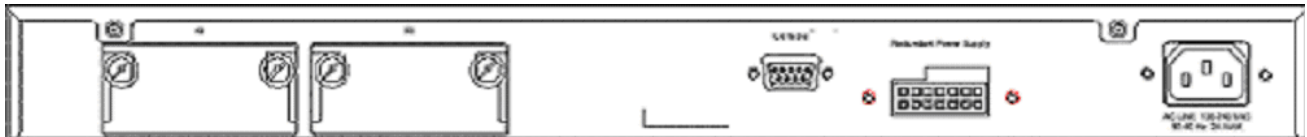
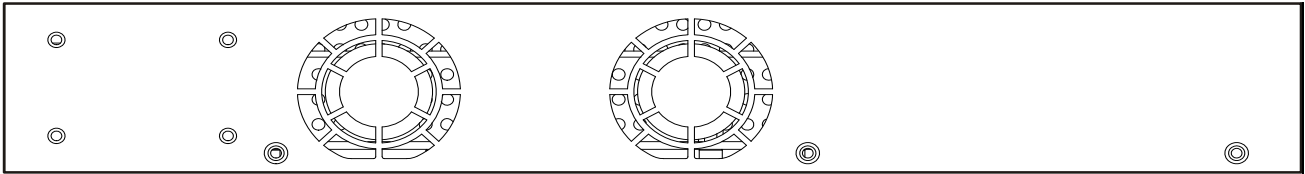

Figure 1- 14. Rear Panel view of DGS-3650

The rear panel includes an outlet for an optional external redundant power supply. When power fails, the optional external RPS will take over all the power immediately and automatically. The AC power connector is a standard three-pronged connector that supports the power cord. Plug-in the female connector of the provided power cord into this socket, and the male side of the cord into a power outlet. The Switch automatically adjusts its power setting to any supply voltage in the range from 100 ~ 240 VAC at 50 ~ 60 Hz.

## Side Panel

The right-hand side panel of the Switch contains a system fan and ventilation along the entire right side. The left hand panel includes a system fan and a heat vent. The system fans are used to dissipate heat. Do not block these openings on either side of the Switch. Leave at least 6 inches of space at the rear and sides of the Switch for proper ventilation. Be reminded that without proper heat dissipation and air circulation, system components might overheat, which could lead to system failure.



**Figure 1- 15. Side Panel of the DGS-3612**

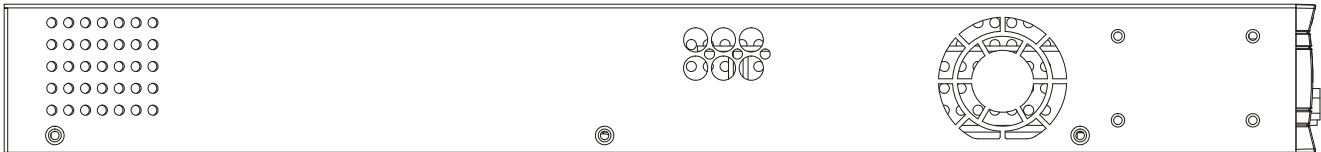

**Figure 1- 16. Side Panel of the DGS-3612G**

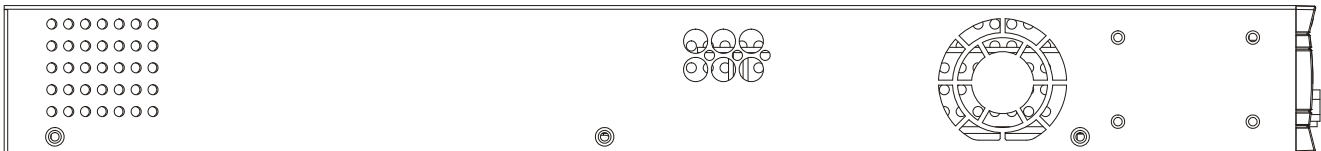

**Figure 1- 17. Side Panel of the DGS-3627**

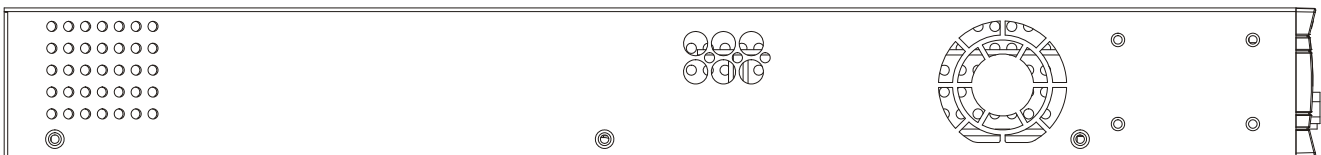

**Figure 1- 18. Side Panel of the DGS-3627G**

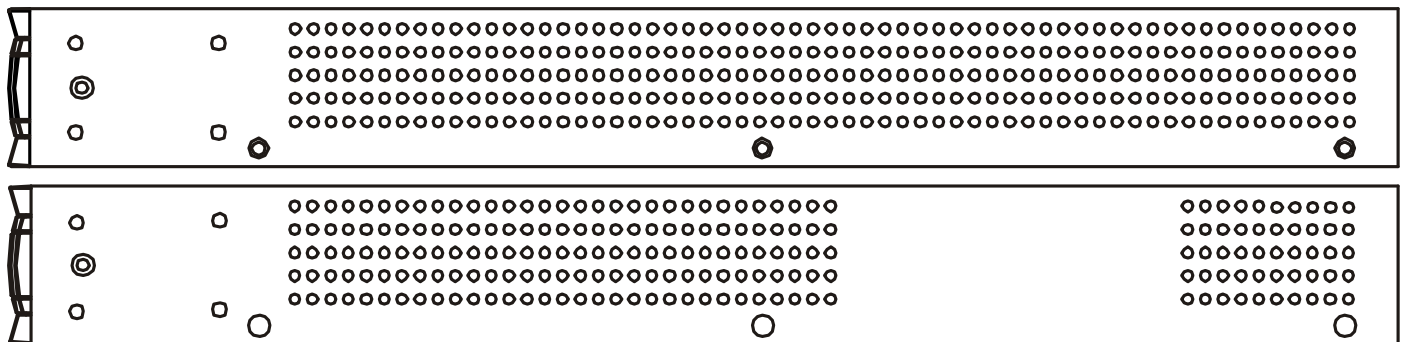

**Figure 1- 19. Side Panels of the DGS-3650**

# Installation

## *Package Contents*

## *Installation Guidelines*

## *Installing the Switch without the Rack*

## *Installing the Switch in a Rack*

## *Mounting the Switch in a Standard 19" Rack*

## *Power On*

## *Power Failure*

## *Installing the SFP Ports*

## *Optional 10GE Uplink Module*

## *External Redundant Power System*

# Package Contents

Open the shipping carton of the Switch and carefully unpack its contents. The carton should contain the following items:

- One switch
- One AC power cord
- This manual on CD
- One mounting kit (two brackets and screws)
- Four rubber feet with adhesive backing
- One DCE RS-232 console cable

If any item is missing or damaged, please contact your local D-Link reseller for replacement.

# Installation Guidelines

The site where you install the Switch may greatly affect its performance. Please follow these guidelines for setting up the Switch.

- Install the Switch on a sturdy, level surface that can support at least 4.24kg (9.35lbs) of weight for the DGS-3612/DGS-3612G/DGS-3627/DGS-3627G, or 6.02kg (13.27lbs) for DGS-3650. Do not place heavy objects on the Switch.
- The power outlet should be within 1.82 meters (6 feet) of the Switch.
- Visually inspect the power cord and see that it is fully secured to the AC/DC power port.
- Make sure that there is proper heat dissipation from and adequate ventilation around the Switch. Leave at least 10 cm (4 inches) of space at the front and rear of the Switch for ventilation.
- Install the Switch in a fairly cool and dry place for the acceptable temperature and humidity operating ranges.
- Install the Switch in a site free from strong electromagnetic field generators (such as motors), vibration, dust, and direct exposure to sunlight.
- When installing the Switch on a level surface, attach the rubber feet to the bottom of the device. The rubber feet cushion the Switch, protect the casing from scratches and prevent it from scratching other surfaces.

## Installing the Switch without the Rack

When installing the Switch on a desktop or shelf, the rubber feet included with the Switch should first be attached. Attach these cushioning feet on the bottom at each corner of the device. Allow enough ventilation space between the Switch and any other objects in the vicinity.

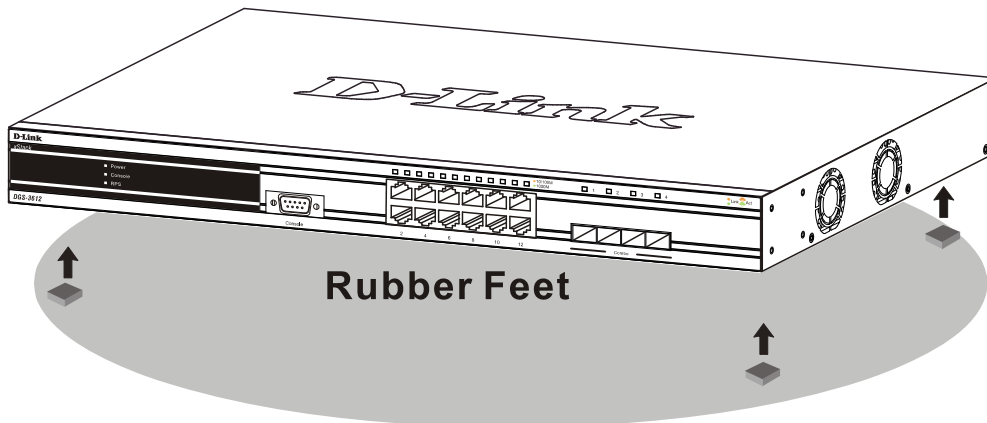

Figure 2 - 1. Prepare Switch for installation on a desktop or shelf

## Installing the Switch in a Rack

The Switch can be mounted in a standard 19" rack. Use the following diagrams to guide you.

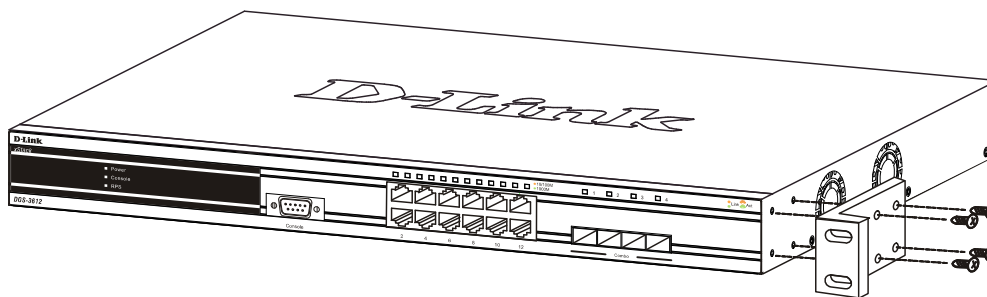

Figure 2 - 2. Fasten mounting brackets to Switch

Fasten the mounting brackets to the Switch using the screws provided. With the brackets attached securely, users can mount the Switch in a standard rack as shown in Figure 2-3 below.

## Mounting the Switch in a Standard 19" Rack



**CAUTION:** Installing systems in a rack without the front and side stabilizers installed could cause the rack to tip over, potentially resulting in bodily injury under certain circumstances. Therefore, always install the stabilizers before installing components in the rack. After installing components in a rack, do not pull more than one component out of the rack on its slide assemblies at one time. The weight of more than one extended component could cause the rack to tip over and may result in injury.

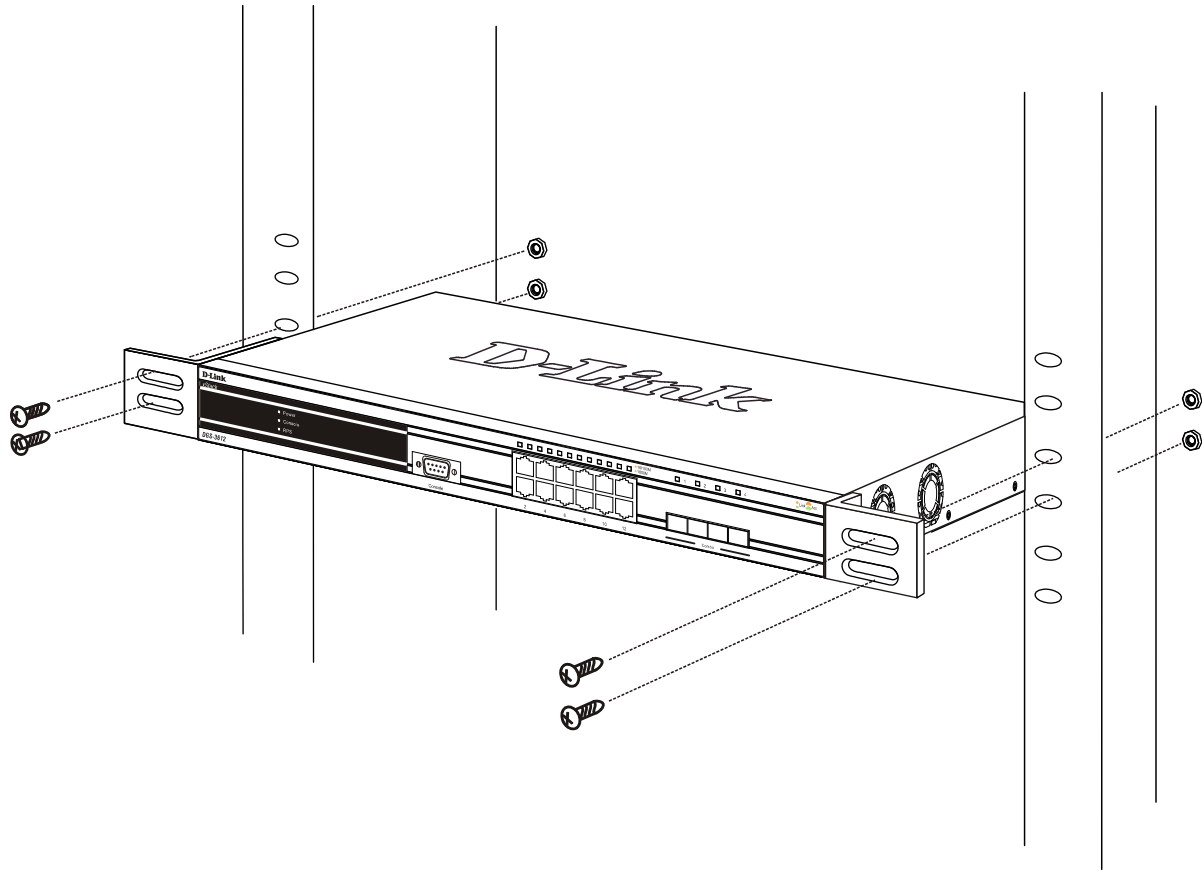

Figure 2 - 3. Installing Switch in a rack

### Power On

Plug one end of the AC power cord into the power connector of the Switch and the other end into the local power source outlet.

After the Switch is powered on, the LED indicators will momentarily blink. This blinking of the LED indicators represents a reset of the system.

### Power Failure

For AC power supply units, as a precaution, in the event of a power failure, unplug the Switch. When power has resumed, plug the Switch back in.

## Installing the SFP Ports

The xStack® DGS-3600 Series switches are equipped with SFP (Small Form Factor Portable) ports, which are to be used with fiber-optical transceiver cabling in order to uplink various other networking devices for a gigabit link that may span great distances. These SFP ports support full-duplex transmissions, have auto-negotiation and can be used with the DEM-210 (100FX-LC), DEM-211 (100FX-LC), DEM-310GT (1000BASE-LX), DEM-311GT (1000BASE-SX), DEM-312GT2 (1000BASE-LX), DEM-314GT (1000BASE-LH), DEM-315GT (1000BASE-ZX), DEM-330T/R (WDM) and DEM-331T/R (WDM) transceivers. See the figure below for installing the SFP ports in the Switch.

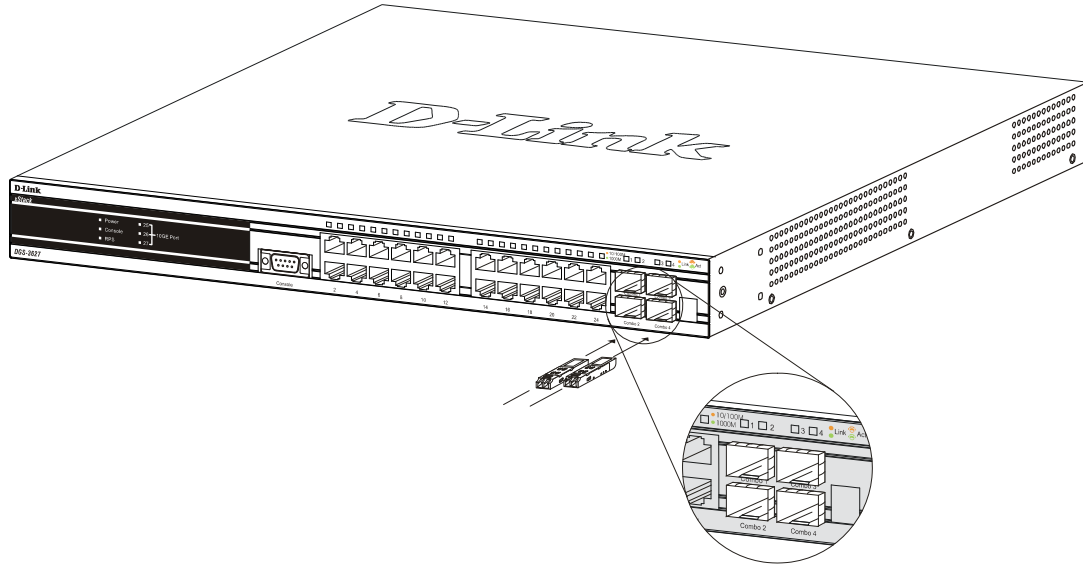

Figure 2 - 4. Inserting the fiber-optic transceivers into the DGS-3600 Series switch

## Optional 10GE Uplink Module

At the rear of the xStack® DGS-3600 Series switches reside optional module slots. This slot may be equipped with the DEM-410X single-port 10GE XFP uplink module, or a DEM-410CX single-port 10GE CX4 uplink module, both sold separately.

Adding the DEM-410X optional module will allow the administrator to add a single-port 10GE stacking module which will transmit information at a rate of ten gigabits a second. This port is compliant with standard IEEE 802.3ae, supports full-duplex transmissions only and is to be used with XFP MSA compliant transceivers.

The DEM-410CX will transfer information at a rate of ten gigabits a second but is used as an uplink module to a network device. Compliant with the IEEE802.3ak standard, this module will use a 4-laned copper connector to transfer information in full-duplex mode, quickly and accurately. User beware, the cable and connector port used for this module is nearly identical to the stacking ports and cables used for stacking in the xStack® Series, but can in no way be interchangeable.

To install these modules, follow the simple steps listed below.



**CAUTION:** Before adding the optional module, make sure to disconnect all power sources connected to the Switch. Failure to do so may result in an electrical shock, which may cause damage, not only to the individual but to the Switch as well.

At the back of the Switch to the left is the slot for the optional module, as shown in Figure 1-18 and Figure 1-19. This slot should be covered with a faceplate that can be easily removed by loosening the screws and pulling off the plate.

Optional Module Slots

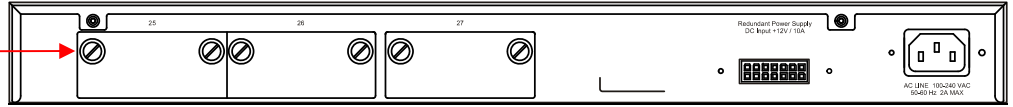

Figure 2 - 5. Optional Module slots at the rear of the DGS-3627 (or DGS-3627G)

Optional Module Slots

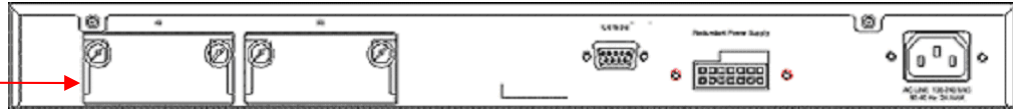

Figure 2 - 6. Optional Module slots at the rear of the DGS-3650

After removing the faceplate, remove the DEM-410X or DEM-410CX optional module from its box. The front panel should resemble the drawings represented here.

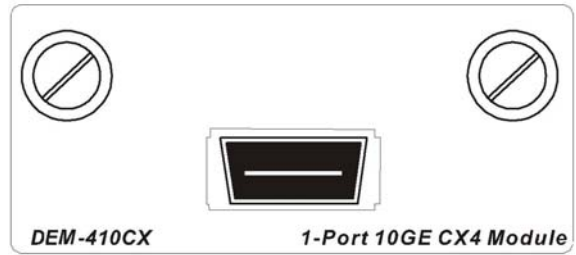
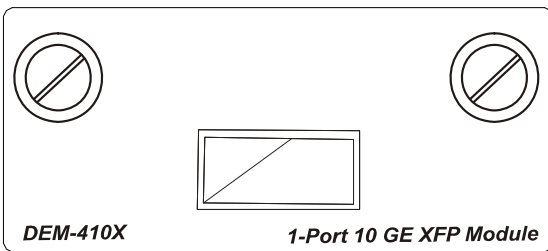

Figure 2 - 7. Front Panel of the DEM-410X and the DEM-410CX

Take the module and gently slide it in to the available slot at the rear of the Switch until it reaches the back, as shown in the following figure. At the back of the slot are two sets of plugs that must be connected to the module. Gently, but firmly push in on the module to secure it to the Switch. The module should fit snugly into the corresponding receptors.

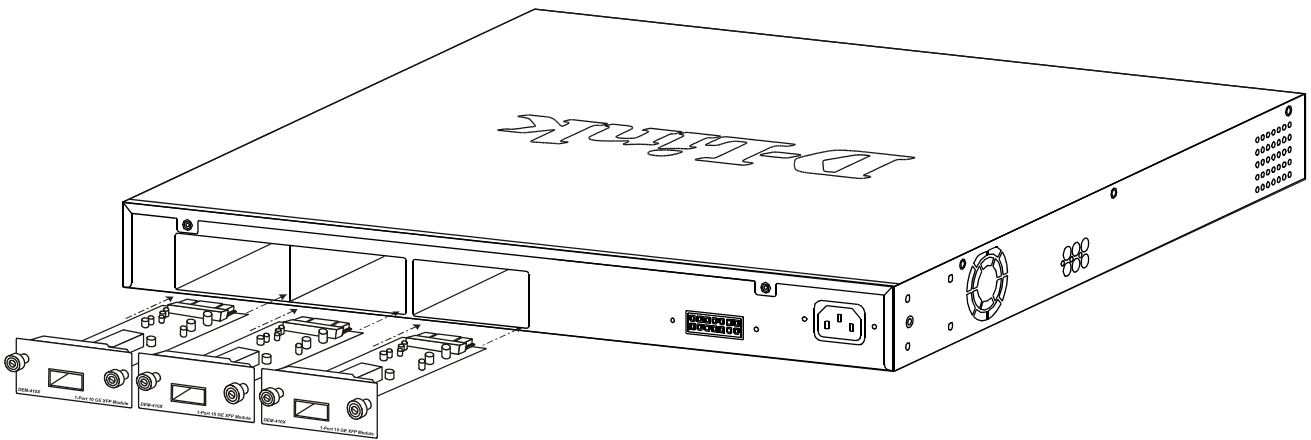

Figure 2 - 8. Inserting the optional modules into the Switch

Now tighten the two screws at adjacent ends of the module into the available screw holes on the Switch. The upgraded DGS-3627/DGS-3627G/DGS-3650 is now ready for use.

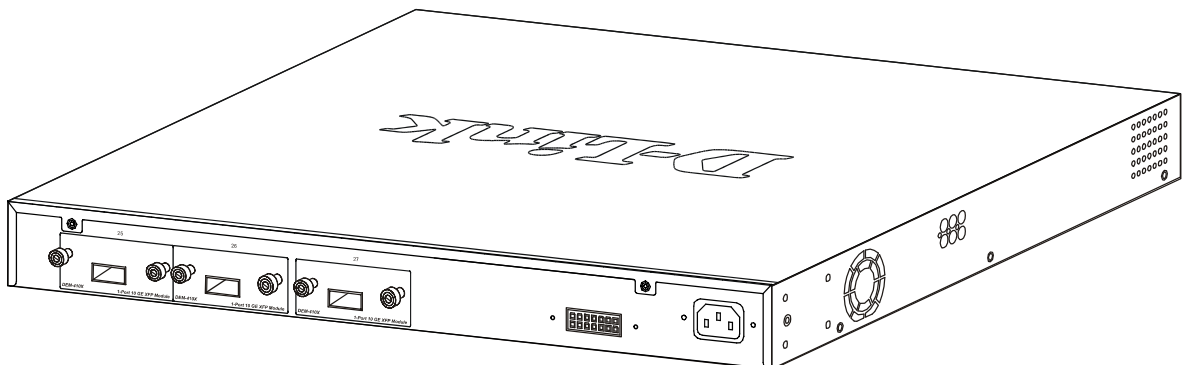

Figure 2 - 9. DGS-3627 with optional module installed



## External Redundant Power System

The xStack® DGS-3600 Series switches are equipped with a redundant power supply feature. Follow the instructions below to connect a RPS power supply (DPS-500) to the DGS-3627/DGS-3627G/DGS-3612G/DGS-3650. The DPS-500 is a redundant power-supply unit designed to conform to the voltage requirements of the switches being supported. DPS-500 can be installed into the DPS-900, or DPS-800.



**CAUTION:** The AC power cord for the Switch should be disconnected before proceeding with installation of the DPS-500.

DGS-3627

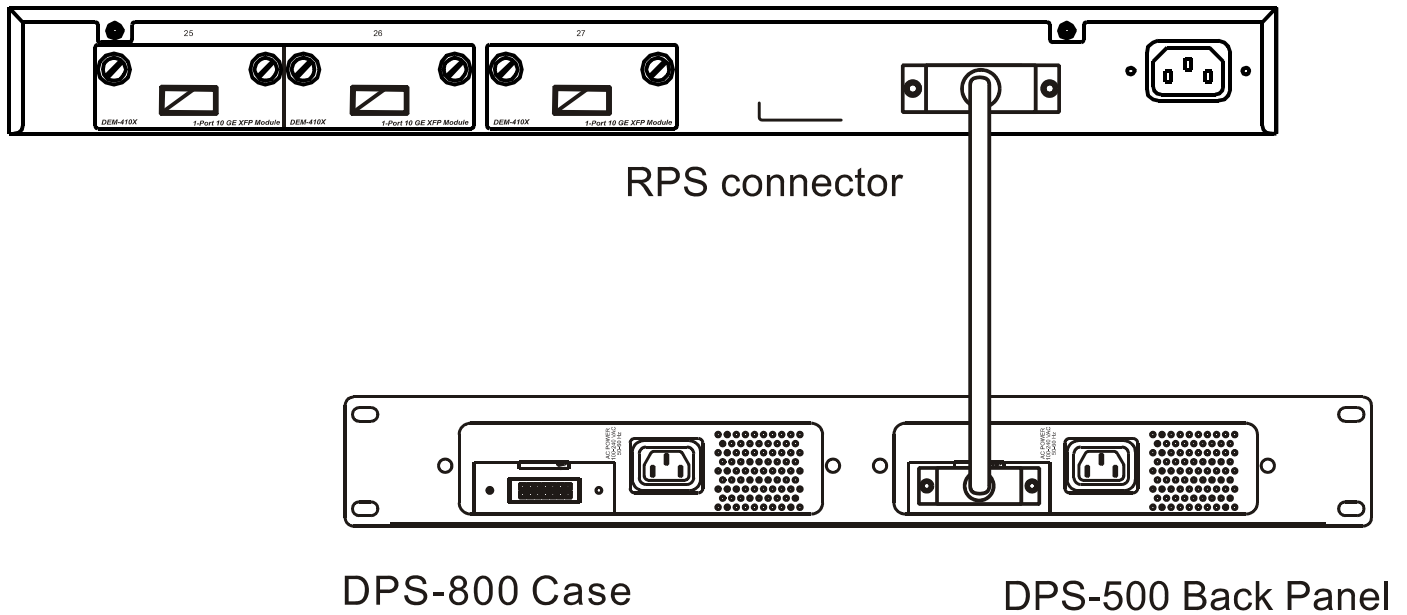

Figure 2 - 10. Installing the DPS-500



**CAUTION:** Installing systems in a rack without the front and side stabilizers installed could cause the rack to tip over, potentially resulting in bodily injury under certain circumstances. Therefore, always install the stabilizers before installing components in the rack. After installing components in a rack, do not pull more than one component out of the rack on its slide assemblies at one time. The weight of more than one extended component could cause the rack to tip over and may result in injury.

## Connect to RPS

The DPS-500 is connected to the Master Switch using a 14-pin DC power cable. A standard, three-pronged AC power cable connects the redundant power supply to the main power source.

### DGS-3627

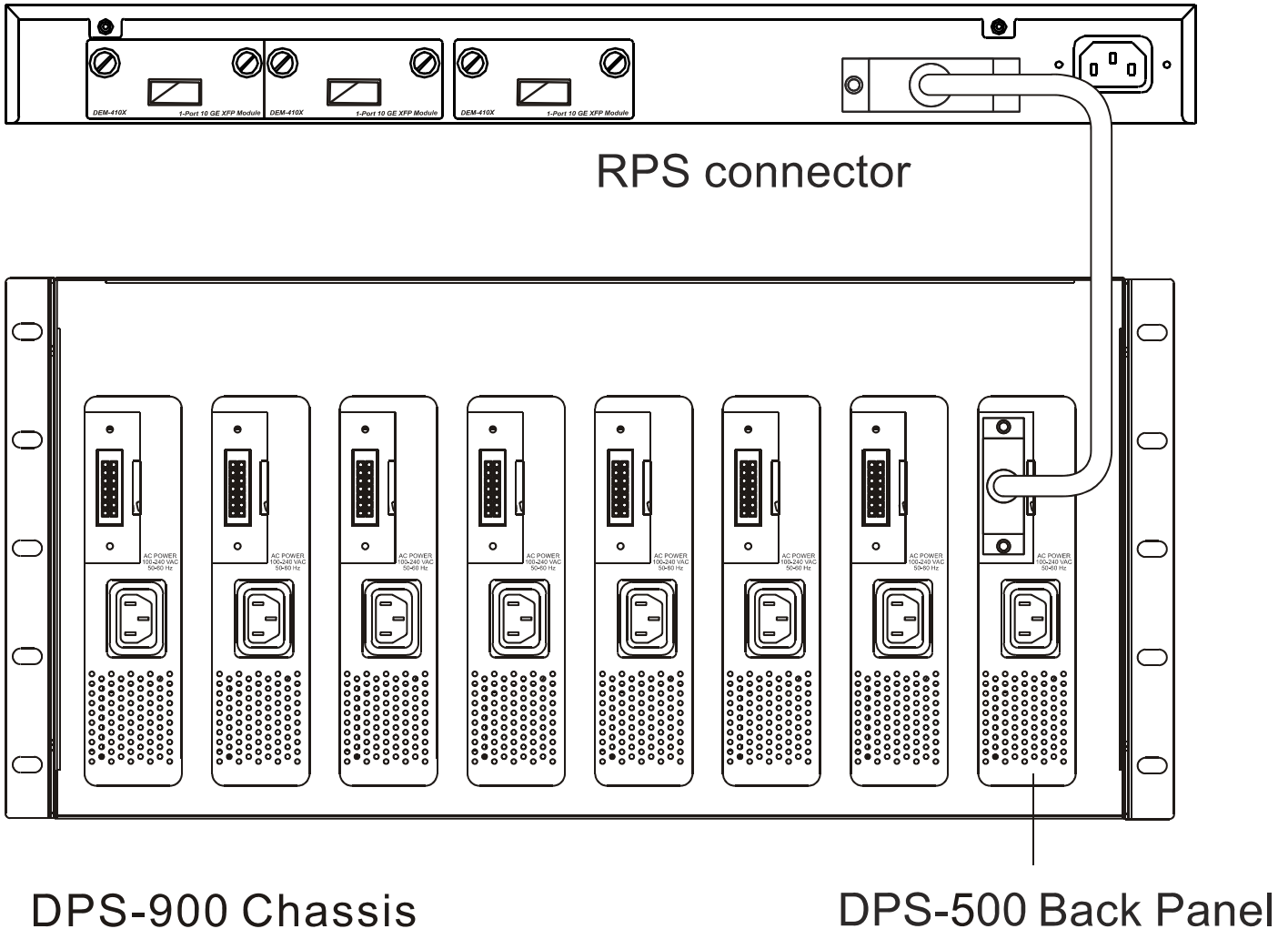

### DPS-900 Chassis

### DPS-500 Back Panel

Figure 2 - 11. The DGS-3627 with the DPS-500 chassis RPS

1. Insert one end of the 14-pin DC power cable into the receptacle on the switch and the other end into the redundant power supply.
2. Using a standard AC power cable, connect the redundant power supply to the main AC power source. A green LED on the front of the DPS-500 will glow to indicate a successful connection.
3. Re-connect the switch to the AC power source. A LED indicator will show that a redundant power supply is now in operation.
4. No change in switch configuration is necessary for this installation.



**NOTE:** See the DPS-500 documentation for more information.



**CAUTION:** Do not use the Switch with any redundant power system other than the DPS-500.

## DPS-200

The xStack® DGS-3612 switch can connect an RPS power supply to the Switch (DPS-200) redundant power-supply unit designed to conform to the voltage requirements of the switches being supported. The DPS-200 is a redundant power-supply unit designed to conform to the voltage requirements of the switches being supported. DPS-200 can be installed into DPS-900, or DPS-800.



**CAUTION:** The AC power cord for the Switch should be disconnected before proceeding with installation of the DPS-200.

## DPS-900

The DPS-900 is a standard-size rack mount (5 standard units in height) designed to hold up to eight DPS-200 redundant power supplies.

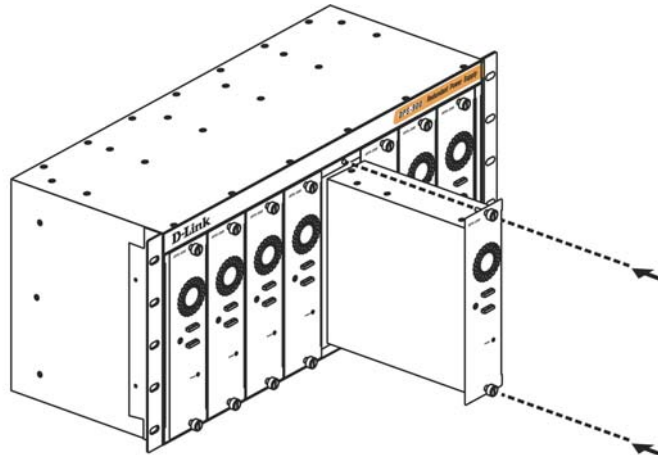

**Figure 2 - 12. Installing the DPS-200 into the DPS-900**

The RPS can be mounted in a standard 19" rack. Use the following diagram to guide you.

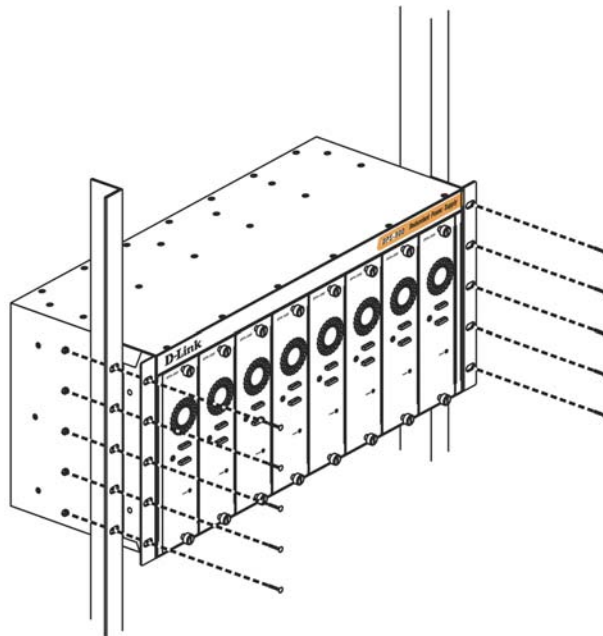

**Figure 2 - 13. Installing the DPS-900 into the equipment rack**



**CAUTION:** Installing systems in a rack without the front and side stabilizers installed could cause the rack to tip over, potentially resulting in bodily injury under certain circumstances. Therefore, always install the stabilizers before installing components in the rack. After installing components in a rack, do not pull more than one component out of the rack on its slide assemblies at one time. The weight of more than one extended component could cause the rack to tip over and may result in injury.

## DPS-800

The DPS-800 is a standard-size rack mount (1 standard unit in height) designed to hold up to two DPS-200 redundant power supplies.

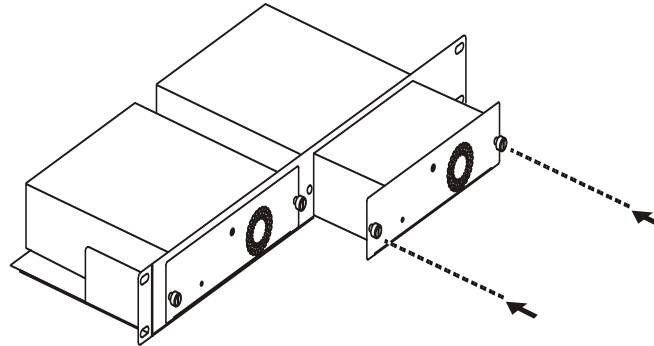

**Figure 2 - 14. Install DPS-200 in DPS-800**

The RPS can be mounted in a standard 19" rack. Use the following diagram to guide you.

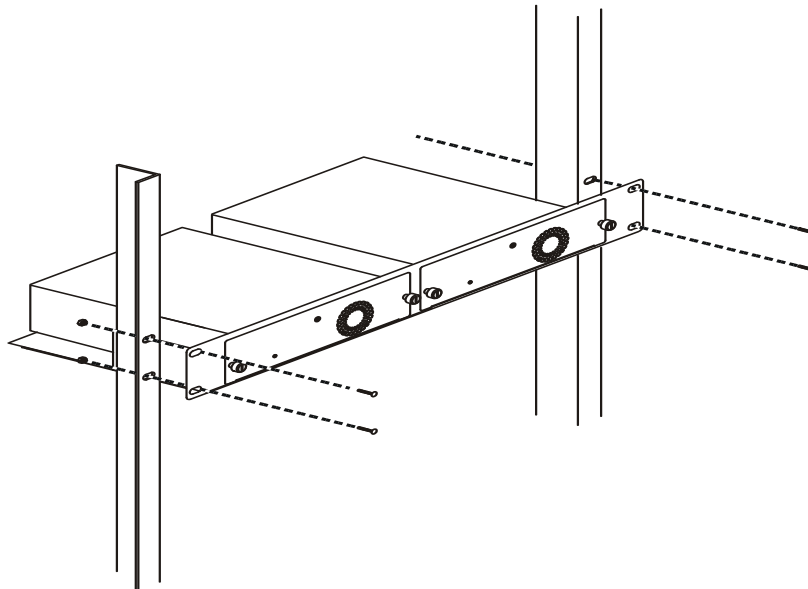

**Figure 2 - 15. Install DPS-800 in an Equipment Rack**

# Connecting the Switch

*Switch to End Node*

*Switch to Hub or Switch*

*Connecting to Network Backbone or Server*



**NOTE:** All 10/100/1000Mbps NWay Ethernet ports can support both MDI-II and MDI-X connections.

## Switch to End Node

End nodes include PCs outfitted with a 10, 100 or 1000 Mbps RJ 45 Ethernet/Fast Ethernet Network Interface Card (NIC) and most routers. An end node can be connected to the Switch via a twisted-pair Category 3, 4, or 5 UTP/STP cable. The end node should be connected to any of the ports of the Switch.

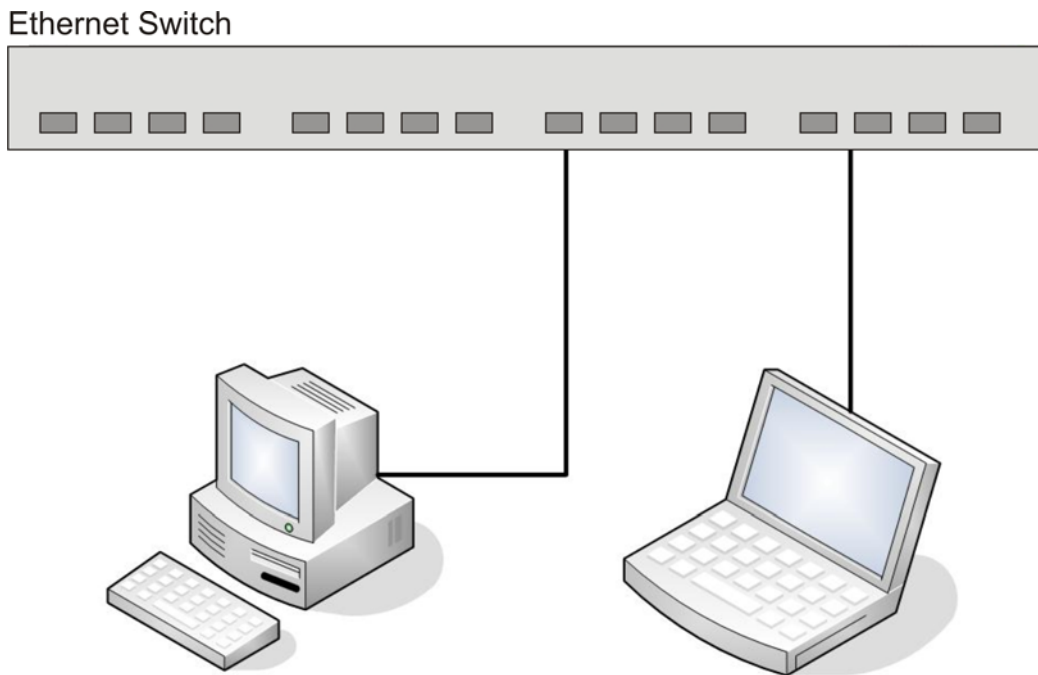

**Figure 3- 1. Switch connected to an end node**

The Link/Act LEDs for each UTP port will light green or amber when the link is valid. A blinking LED indicates packet activity on that port.

## Switch to Hub or Switch

These connections can be accomplished in a number of ways using a normal cable.

A 10BASE-T hub or switch can be connected to the Switch via a twisted-pair Category 3, 4 or 5 UTP/STP cable.

A 100BASE-TX hub or switch can be connected to the Switch via a twisted-pair Category 5 UTP/STP cable.

A 1000BASE-T switch can be connected to the Switch via a twisted pair Category 5e UTP/STP cable.

A switch supporting a fiber-optic uplink can be connected to the Switch's SFP ports via fiber-optic cabling.

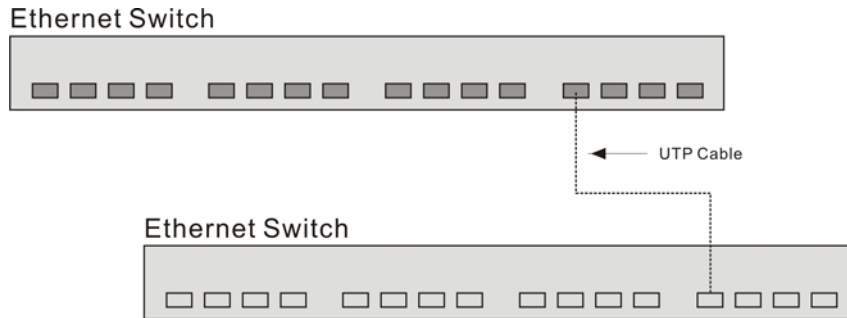

**Figure 3- 2. Switch connected to a normal (non-Uplink) port on a hub or switch using a straight or crossover cable**



**NOTICE:** When the SFP transceiver acquires a link, the associated integrated 10/100/1000BASE-T port is disabled.

## Connecting to Network Backbone or Server

The two Mini-GBIC combo ports are ideal for linking to a network backbone or server. The copper ports operate at a speed of 1000, 100, or 10Mbps in full duplex mode. The fiber optic ports can operate at 1000Mbps in full duplex mode. Connections to the Gigabit Ethernet ports are made using fiber optic cable or Category 5 copper cable, depending on the type of port. A valid connection is indicated when the Link LED is lit.

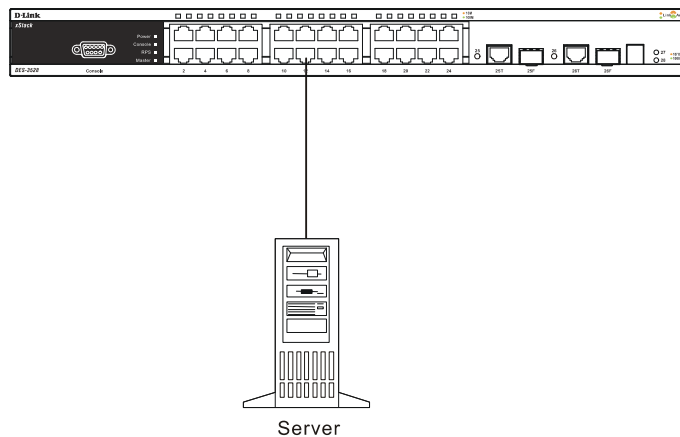

**Figure 3- 3. Connecting the Switch to a server, PC or switch stack**

# Introduction to Switch Management

## *Management Options*

### *Connecting the Console Port (RS-232 DCE)*

### *Managing the Switch for the First Time*

### *Password Protection*

### *SNMP Settings*

### *IP Address Assignment*

## Management Options

This system may be managed out-of-band through the console port on the front panel or in-band using Telnet. The user may also choose the web-based management, accessible through a web browser.

### **1. Web-based Management Interface**

After successfully installing the Switch, the user can configure the Switch, monitor the LED panel, and display statistics graphically using a web browser, such as Netscape Navigator (version 6.2 and higher) or Microsoft® Internet Explorer (version 5.0 and higher).

### **2. SNMP-Based Management**

The Switch can be managed with an SNMP-compatible console program. The Switch supports SNMP version 1.0, version 2.0 and version 3.0. The SNMP agent decodes the incoming SNMP messages and responds to requests with MIB objects stored in the database. The SNMP agent updates the MIB objects to generate statistics and counters.

### **3. Command Line Console Interface through the Serial Port**

The user can also connect a computer or terminal to the serial console port to access the Switch. The command-line-driven interface provides complete access to all Switch management features.

## Connecting the Console Port (RS-232 DCE)

The Switch provides an RS-232 serial port that enables a connection to a computer or terminal for monitoring and configuring the Switch. This port is a female DB-9 connector, implemented as a Data Communication Equipment (DCE) connection.

To use the console port, you need the following equipment:

- A terminal or a computer with both a serial port and the ability to emulate a terminal.
- A null modem or straight RS-232 cable with a female DB-9 connector for the console port on the Switch.

**To connect a terminal to the console port:**

1. Connect the female connector of the RS-232 cable directly to the console port on the Switch, and tighten the captive retaining screws.
2. Connect the other end of the cable to a terminal or to the serial connector of a computer running terminal emulation software. Set the terminal emulation software as follows:
3. Select the appropriate serial port (COM port 1 or COM port 2).
4. Set the data rate to 115200 baud.
5. Set the data format to 8 data bits, 1 stop bit, and no parity.

6. Set flow control to none.
7. Under Properties, select VT100 for Emulation mode.
8. Select Terminal keys for Function, Arrow, and Ctrl keys. Ensure that you select Terminal keys (not Windows keys).



**NOTE:** When you use HyperTerminal with the Microsoft® Windows® 2000 operating system, ensure that you have Windows 2000 Service Pack 2 or later installed. Windows 2000 Service Pack 2 allows you to use arrow keys in HyperTerminal's VT100 emulation. See [www.microsoft.com](http://www.microsoft.com) for information on Windows 2000 service packs.

9. After you have correctly set up the terminal, plug the power cable into the power receptacle on the back of the Switch. The boot sequence appears in the terminal.
10. After the boot sequence completes, the console login screen displays.
11. If you have not logged into the command line interface (CLI) program, press the Enter key at the User name and password prompts. There is no default user name and password for the Switch. The administrator must first create user names and passwords. If you have previously set up user accounts, log in and continue to configure the Switch.
12. Enter the commands to complete your desired tasks. Many commands require administrator-level access privileges. Read the next section for more information on setting up user accounts. See the *xStack® DGS-3600 Series CLI Manual* on the documentation CD for a list of all commands and additional information on using the CLI.
13. When you have completed your tasks, exit the session with the logout command or close the emulator program.
14. Make sure the terminal or PC you are using to make this connection is configured to match these settings.

If you are having problems making this connection on a PC, make sure the emulation is set to VT-100. You will be able to set the emulation by clicking on the **File** menu in your HyperTerminal window, clicking on **Properties** in the drop-down menu, and then clicking the **Settings** tab. This is where you will find the **Emulation** options. If you still do not see anything, try rebooting the Switch by disconnecting its power supply.

Once connected to the console, the screen below will appear on your console screen. This is where the user will enter commands to perform all the available management functions. The Switch will prompt the user to enter a user name and a password. Upon the initial connection, there is no user name or password and therefore just press enter twice to access the command line interface.

```
DGS-3650 Gigabit Ethernet Switch
Command Line Interface

Firmware: Build 2.80.B16
Copyright(C) 2010 D-Link Corporation. All rights reserved.
```

**Figure 4- 1. Initial screen after first connection**



## Managing the Switch for the First Time

The Switch supports user-based security that can allow you to prevent unauthorized users from accessing the Switch or changing its settings. This section tells how to log onto the Switch.



**NOTE:** The passwords used to access the Switch are case-sensitive; therefore, "S" is not the same as "s."

When you first connect to the Switch, you will be presented with the first login screen.



**NOTE:** Press Ctrl+R to refresh the screen. This command can be used at any time to force the console program in the Switch to refresh the console screen.

Press **Enter** in both the Username and Password fields. You will be given access to the command prompt **DGS-3627G:5#** shown below:

There is no initial username or password. Leave the Username and Password fields blank.

```
DGS-3650 Gigabit Ethernet Switch
Command Line Interface

Firmware: Build 2.80.B16
Copyright(C) 2010 D-Link Corporation. All rights reserved.

UserName:
PassWord:

DGS-3650:admin#_
```

**Figure 4- 2. Command Prompt**



**NOTE:** The first user automatically gets Administrator level privileges. It is recommended to create at least one Admin-level user account for the Switch.

# Password Protection

The Switch does not have a default user name and password. One of the first tasks when settings up the Switch is to create user accounts. Once logged in using a predefined administrator-level user name, users will have privileged access to the Switch's management software.

After your initial login, define new passwords for both default user names to prevent unauthorized access to the Switch, and record the passwords for future reference.

To create an administrator-level account for the Switch, follow these steps:

At the CLI login prompt, enter **create account admin** followed by the *<user name>* and press the Enter key.

The switch will then prompt the user for a password. Type the *<password>* used for the administrator account being created and press the **Enter** key.

Again, the user will be prompted to enter the same password again to verify it. Type the same password and press the Enter key.

Successful creation of the new administrator account will be verified by a Success message.



**NOTE:** Passwords are case sensitive. User names and passwords can be up to 15 characters in length.

The sample below illustrates a successful creation of a new administrator-level account with the user name "newmanager".

```
DGS-3650:admin#create account admin newmanager
Command: create account admin newmanager

Enter a case-sensitive new password:*****
Enter the new password again for confirmation:*****

Success.

DGS-3650:admin#
```

**Figure 4- 3. Creating a new account**



**NOTICE:** CLI configuration commands only modify the running configuration file and are not saved when the Switch is rebooted. To save all your configuration changes in nonvolatile storage, you must use the save command to copy the running configuration file to the startup configuration.

## SNMP Settings

Simple Network Management Protocol (SNMP) is an OSI Layer 7 (Application Layer) designed specifically for managing and monitoring network devices. SNMP enables network management stations to read and modify the settings of gateways, routers, switches, and other network devices. Use SNMP to configure system features for proper operation, monitor performance and detect potential problems in the Switch, switch group or network.

Managed devices that support SNMP include software (referred to as an agent), which runs locally on the device. A defined set of variables (managed objects) is maintained by the SNMP agent and used to manage the device. These objects are defined in a Management Information Base (MIB), which provides a standard presentation of the information controlled by the on-board SNMP agent. SNMP defines both the format of the MIB specifications and the protocol used to access this information over the network.

The Switch supports SNMP versions 1, 2c, and 3. You can specify which version of SNMP you want to use to monitor and control the Switch. The three versions of SNMP vary in the level of security provided between the management station and the network device.

In SNMP v.1 and v.2, user authentication is accomplished using 'community strings', which function like passwords. The remote user SNMP application and the Switch SNMP must use the same community string. SNMP packets from any station that has not been authenticated are ignored (dropped).

The default community strings for the Switch used for SNMP v.1 and v.2 management access are:

- public - Allows authorized management stations to retrieve MIB objects.
- private - Allows authorized management stations to retrieve and modify MIB objects.

SNMP v.3 uses a more sophisticated authentication process that is separated into two parts. The first part is to maintain a list of users and their attributes that are allowed to act as SNMP managers. The second part describes what each user on that list can do as an SNMP manager.

The Switch allows groups of users to be listed and configured with a shared set of privileges. The SNMP version may also be set for a listed group of SNMP managers. Thus, you may create a group of SNMP managers that are allowed to view read-only information or receive traps using SNMP v.1 while assigning a higher level of security to another group, granting read/write privileges using SNMP v.3.

Using SNMP v.3 individual users or groups of SNMP managers can be allowed to perform or be restricted from performing specific SNMP management functions. The functions allowed or restricted are defined using the Object Identifier (OID) associated with a specific MIB. An additional layer of security is available for SNMP v.3 in that SNMP messages may be encrypted. To read more about how to configure SNMP v.3 settings for the Switch read the section entitled Management.

## Traps

Traps are messages that alert network personnel of events that occur on the Switch. The events can be as serious as a reboot (someone accidentally turned OFF the Switch), or less serious like a port status change. The Switch generates traps and sends them to the trap recipient (or network manager). Typical traps include trap messages for Authentication Failure, Topology Change and Broadcast/Multicast Storm.

## MIBs

The Switch in the Management Information Base (MIB) stores management and counter information. The Switch uses the standard MIB-II Management Information Base module. Consequently, values for MIB objects can be retrieved from any SNMP-based network management software. In addition to the standard MIB-II, the Switch also supports its own proprietary enterprise MIB as an extended Management Information Base. Specifying the MIB Object Identifier may also retrieve the proprietary MIB. MIB values can be either read-only or read-write.

## IP Address Assignment

Each Switch must be assigned its own IP Address, which is used for communication with an SNMP network manager or other TCP/IP application (for example BOOTP, TFTP). The Switch's default IP address is 10.90.90.90. You can change the default Switch IP address to meet the specification of your networking address scheme.

The Switch is also assigned a unique MAC address by the factory. This MAC address cannot be changed, and can be found by entering the command "show switch" into the command line interface, as shown below.

```
DGS-3650:admin#show switch
Command: show switch

Device Type       : DGS-3650 Gigabit Ethernet Switch
MAC Address       : 00-19-5B-F4-B6-80
IP Address        : 10.90.90.90 (Manual)
VLAN Name         : default
Subnet Mask       : 255.0.0.0
Default Gateway   : 0.0.0.0
Boot PROM Version : Build 1.10-B06
Firmware Version  : Build 2.80.B16
Hardware Version  : 2A1G
Serial Number     :
System Name       :
System Location   :
System Contact    :
Spanning Tree     : Disabled
GVRP              : Disabled
IGMP Snooping    : Disabled
MLD Snooping     : Disabled
RIP               : Disabled
DVMRP            : Disabled
PIM               : Disabled
OSPF              : Disabled
OSPFv3           : Disabled
BGP               : Disabled

CTRL+C  ESC  q Quit  SPACE  n Next Page  ENTER Next Entry  a All
```

**Figure 4- 4. Show switch command**

The Switch's MAC address can also be found from the Web management program on the **Switch Information (Basic Settings)** window on the **Configuration** folder.

The IP address for the Switch must be set before it can be managed with the Web-based or SNMP manager, Telnet or SSH. The Switch IP address can be automatically set using BOOTP or DHCP protocols, in which case the actual address assigned to the Switch must be known.

The IP address may be set using the Command Line Interface (CLI) over the console serial port as follows:

Starting at the command line prompt, enter the commands

**config ipif System ipaddress xxx.xxx.xxx.xxx/yyy.yyy.yyy.yyy**

Where the x's represent the IP address to be assigned to the IP interface named System and the y's represent the corresponding subnet mask.

Alternatively, you can enter **config ipif System ipaddress xxx.xxx.xxx.xxx/z**. Where the x's represent the IP address to be assigned to the IP interface named System and the z represents the corresponding number of subnets in CIDR notation.

The IP interface named System on the Switch can be assigned an IP address and subnet mask, and then be used to connect a management station to the Switch's Telnet or Web-based management agent.

```
DGS-3650:admin#config ipif System ipaddress 10.24.22.5/255.0.0.0
Command: config ipif System ipaddress 10.24.22.5/8

Success.

DGS-3650:admin#
```

**Figure 4- 5. Assigning the Switch an IP Address**

In the above example, the Switch was assigned an IP address of 10.24.22.5 with a subnet mask of 255.0.0.0. The user may also use the CIDR form to set the address (10.24.22.5/8). The system message **Success** indicates that the command was executed successfully. The Switch can now be configured and managed via Telnet and the CLI or via the Web-based management.

# **Web-based Switch Configuration**

*Introduction*

*Logging in to the Web Manager*

*Web-based User Interface*

*Web Pages*

## **Introduction**

All software functions of the xStack® DGS-3600 Series switches can be managed, configured and monitored via the embedded Web-based (HTML) interface. Manage the Switch from remote stations anywhere on the network through a standard browser. The browser acts as a universal access tool and can communicate directly with the Switch using the HTTP protocol.

The Web-based management module and the Console program (and Telnet) are different ways to access the same internal switching software and configure it. Thus, all settings encountered in web-based management are the same as those found in the console program.

## Logging in to the Web Manager

To begin managing the Switch, simply run the browser installed on your computer and point it to the IP address you have defined for the device. The URL in the address bar should read something like: `http://123.123.123.123`, where the numbers 123 represent the IP address of the Switch.



**NOTE:** The factory default IP address is 10.90.90.90.

This opens the management module's user authentication window, as seen below.



**Figure 5 - 1 Enter Network Password window**

As there is no default User name or Password, click **OK** to proceed. This will open the Web-based user interface. The Switch management features available in the Web-based manager are explained below.

# Web-based User Interface

The user interface provides access to various Switch configuration and management screens, allows the user to view performance statistics, and permits graphical monitoring of the system status.

## Areas of the User Interface

The figure below shows the user interface. Three distinct areas divide the user interface, as described in the table.

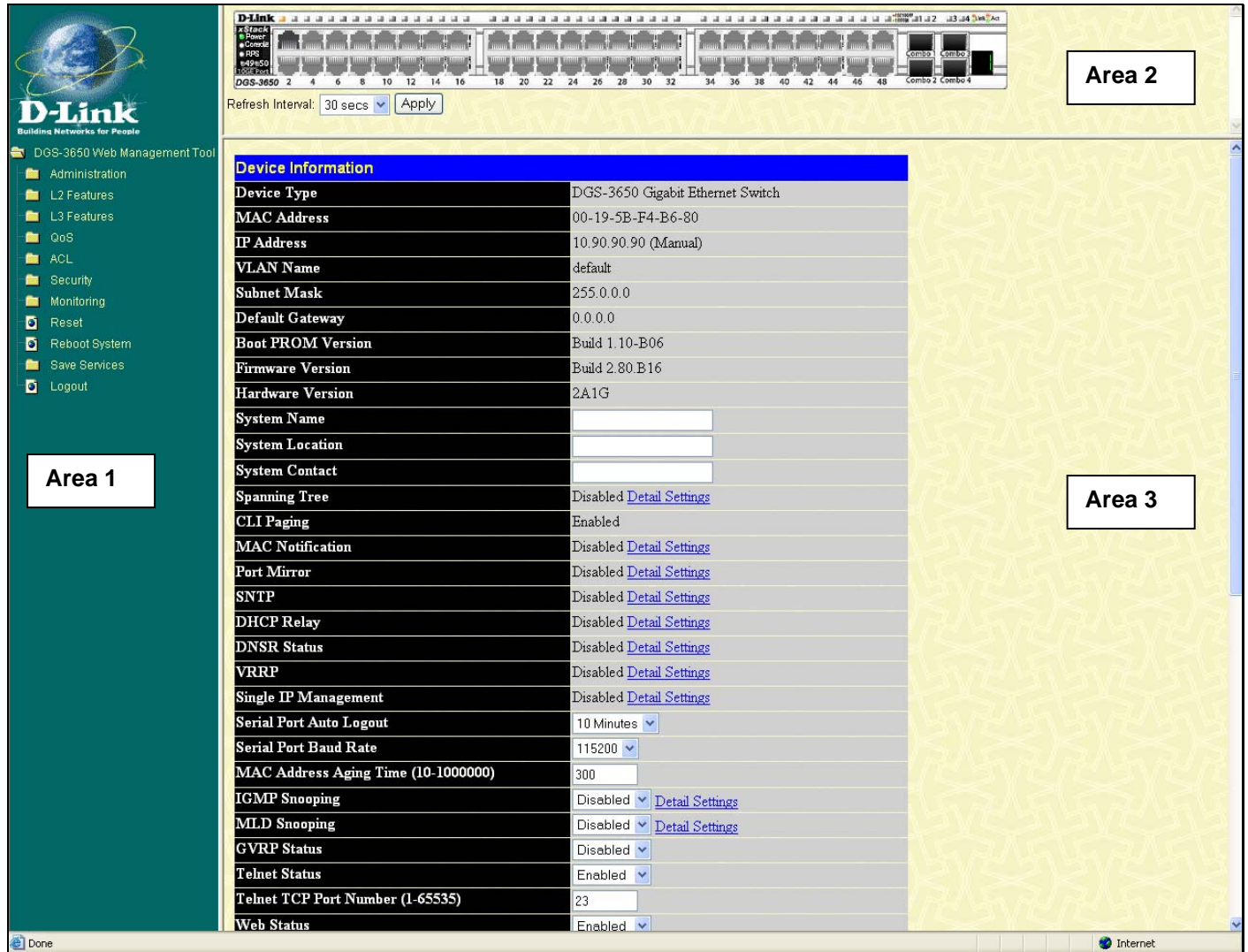

Figure 5 - 2 Main Web Manager window

Area	Function
Area 1	Select the menu or window to display. Open folders and click the hyperlinked menu buttons and subfolders contained within them to display menus. Click the D-Link logo to go to the D-Link Website.
Area 2	Presents a graphical near real-time image of the front panel of the Switch. This area displays the Switch's ports and expansion modules, showing port activity, duplex mode, or flow control, depending on the specified mode.  Some management functions, including port configuration are accessible here.
Area 3	Presents switch information based on user selection and the entry of configuration data.



## Web Pages

When connecting to the management mode of the Switch with a Web browser, a login screen is displayed. Initially, there is no user name or password to access the Switch's management mode. Click the **OK** button to proceed.

Below is a list of the main folders available in the Web interface:

**Administration** – Contains the following folders and windows: IP Address, IP MTU Settings, Stacking, Port Configuration, User Accounts, Password Encryption, Mirror, System Log, System Severity Settings, Command Logging Settings, SNTP Settings, MAC Notification Settings, TFTP Services, File System Services, RCP, Ping Test, IPv6 Neighbor, DHCP Auto Configuration Settings, DHCP/BOOTP Relay, DHCP/BOOTP Local Relay Settings, DHCPv6 Relay, Layer 2 Protocol Tunneling Settings, RSPAN, SNMP Manager, Trap Source Interface Settings, sFlow, and Single IP Management Settings.

**L2 Features** – Contains the following folders and windows: VLAN, Trunking, IGMP Snooping, MLD Snooping, Loopback Detection Global Settings, Spanning Tree, Forwarding & Filtering, LLDP, Q-in-Q, ERPS, DULD Settings, and NLB Multicast FDB Settings.

**L3 Features** – Contains the following folders and windows: Interface Settings, MD5 Key Settings, Route Redistribution Settings, Multicast Static Route Settings, Static/Default Route Settings, Route Preference Settings, Static ARP Settings, Gratuitous ARP Settings, Policy Route Settings, ECMP Algorithm Settings, IP Tunnel Settings, RIP, OSPF, DHCP Server, Filter DHCP Server, DNS Relay, DNS Resolver, VRRP, IP Multicast Routing Protocol, BGP, and IP Route Filter.

**QoS** – Contains the following folders and windows: 802.1p Settings, Bandwidth Control, HOL Prevention Settings, and Schedule Settings.

**ACL** – Contains the following folders and windows: Time Range, Access Profile Table, ACL Flow Meter, and CPU Interface Filtering.

**Security** – Contains the following folders and windows: Authorization Attributes State Settings, Traffic Control, Port Security, IP-MAC-Port Binding, 802.1X, Web-based Access Control (WAC), Trust Host, BPDU Attack Protection Settings, ARP Spoofing Prevention Settings, Access Authentication Control, MAC-based Access Control, Safeguard Engine, Traffic Segmentation, SSL, SSH, Common Authentication, and Japanese Web-based Access Control (JWAC).

**Monitoring** – Contains the following folders and windows: Device Status, Module Information, DRAM & Flash Utilization, CPU Utilization, Port Utilization, Packets, Errors, Packet Size, Browse Router Port, Browse MLD Router Port, VLAN Status, VLAN Status Port, Port Access Control, MAC Address Table, IGMP Snooping Group, MLD Snooping Group, Trace Route, IGMP Snooping Forwarding, MLD Snooping Forwarding, IP Forwarding Table, Routing Table, Browse IP Multicast Forwarding Table, Browse IP Multicast Interface Table, Browse IGMP Group Table, DVMRP Monitor, PIM Monitor, OSPF Monitor, Switch Logs, Browse ARP Table, Session Table, and MAC-based Access Control Authentication Status.

**Reset, Reboot System** and **Logout** links are displayed in the main directory.

**Save Services** – Contains the following folders and windows: Save Changes and Current Configuration Settings.



**NOTE:** Be sure to configure the user name and password in the User Accounts menu before connecting the Switch to the greater network.

# Appendix A

## Technical Specifications

Specifications listed here apply to all Switches in the DGS-3600 Series except where otherwise noted.

General	
<b>Protocols</b>	IEEE 802.3 10BASE-T Ethernet IEEE 802.3u 100BASE-TX Fast Ethernet IEEE 802.3ab 1000BASE-T Gigabit Ethernet IEEE 802.3z 1000BASE-T (SFP “Mini GBIC”) IEEE 802.3ae (10G Optional Modules) IEEE 802.1D/w/s Spanning Tree (Rapid, Multiple) IEEE 802.1P/Q VLAN IEEE 802.1p Priority Queues IEEE 802.1v Protocol VLAN IEEE 802.1X Port-based Network Access Control IEEE 802.3 NWay auto-negotiation IEEE 802.3ad Link Aggregation Control IEEE 802.3x Full-duplex Flow Control IEEE 802.1u Fast Ethernet
<b>Standards</b>	CSMA/CD
<b>Data Transfer Rates:</b>	Half-duplex      Full-duplex
<b>Ethernet</b>	10 Mbps          20Mbps
<b>Fast Ethernet</b>	100Mbps          200Mbps
<b>Gigabit Ethernet</b>	N/A                2000Mbps
<b>Fiber Optic</b>	SFP (Mini GBIC) Support IEEE 802.3u 100BASE-FX (DEM-210 transceiver) IEEE 802.3u 100BASE-FX (DEM-211 transceiver) IEEE 802.3z 1000BASE-LX (DEM-310GT transceiver) IEEE 802.3z 1000BASE-SX (DEM-311GT transceiver) IEEE 802.3z 1000BASE-SX (DEM-312GT2 transceiver) IEEE 802.3z 1000BASE-LH (DEM-314GT transceiver) IEEE 802.3z 1000BASE-ZX (DEM-315GT transceiver) IEEE 802.3z WDM Transceiver (DEM-330T transceiver) IEEE 802.3z WDM Transceiver (DEM-330R transceiver) IEEE 802.3z WDM Transceiver (DEM-331T transceiver) IEEE 802.3z WDM Transceiver (DEM-331R transceiver)
<b>XFP Support</b>	IEEE 802.3ae 10G Fiber-Optic
<b>CX4 Support</b>	IEEE 802.3ak 10G Copper
<b>Topology</b>	Duplex Ring, Duplex Chain

<b>Network Cables</b>	Cat.5 Enhanced for 1000BASE-T UTP Cat.5, Cat. 5 Enhanced for 100BASE-TX UTP Cat.3, 4, 5 for 10BASE-T EIA/TIA-568 100-ohm screened twisted-pair (STP)(100m)
<b>Number of Ports</b>	DGS-3612: 12 x 10/100/1000Mbps copper ports 4 x Combo 100/1000Mbps SFP ports DGS-3612G: 12 x 100/1000Mbps SFP ports 4 x Combo 10/100/1000Mbps ports DGS-3627: 24 x 10/100/1000Mbps ports 4 x 1000Mbps Combo SFP ports 3 available slots for optional 10GE modules DGS-3627G: 24 x 1000Mbps SFP ports 4 x 10/100/1000Mbps Combo Ports 3 available slots for optional 10GE modules DGS-3650: 48 x 10/100/1000 Mbps ports 4 x 1000Mbps Combo SFP Ports 2 available slots for optional 10GE modules

<b>Physical and Environmental</b>	
<b>Internal Power Supply Redundant Power Supply</b>	AC Input: 100 - 240 VAC, 50-60 Hz Output: 12V, 10A (Max)
<b>Power Consumption</b>	DGS-3612 – 45W DGS-3612G – 50W DGS-3627 – 95W DGS-3627G – 77W DGS-3650 – 137W
<b>DC Fans:</b>	DGS-3612 - Two 40mm x 40mm x 20mm fans DGS-3612G – Three 40mm x 40mm x 20mm; one 50mm x 50mm x 20mm fans DGS-3627 – Four 40mm x 40mm x 20mm; one 50mm x 50mm x 20mm; one 44mm x 44mm x 11mm DGS-3627G – Four 40mm x 40mm x 20mm; one 50mm x 50mm x 20mm fans DGS-3650 – Two 40mm x 40mm x 20mm; three 40mm x 40mm x 10mm; one 75.7mm x 75.7mm x 30mm fans; one 44mm x 44mm x 11mm
<b>Operating Temperature</b>	0 - 40°C
<b>Storage Temperature</b>	-40 - 70°C
<b>Humidity</b>	5 - 95% non-condensing
<b>Dimensions</b>	DGS-3612 – 441 mm x 310 mm x 44 mm DGS-3612G/DGS-3627/DGS-3627G/DGS-3650 - 441mm x 389mm x 44mm
<b>Weight</b>	DGS-3612 - 3.8kg (8.38 lbs) DGS-3612G – 5kg (11.02 lbs) DGS-3627, DGS-3627G – 5.5kg (12.13 lbs) DGS-3650 – 6kg (13.23 lbs)
<b>EMI</b>	CE class A, FCC Class A , C-Tick, VCCI

**Physical and Environmental**

<b>Safety</b>	CB Report, CUL
---------------	----------------

**Performance**

<b>Transmission Method</b>	Store-and-forward
<b>Packet Buffer</b>	2 MB per device
<b>Packet Filtering / Forwarding Rate</b>	14,881 pps (10M port) 148.810 pps (100M port) 1,488,100 pps (1Gbps port)
<b>MAC Address Learning</b>	Automatic update. Supports 16K MAC address.
<b>Priority Queues</b>	8 Priority Queues per port.
<b>Forwarding Table Age Time</b>	Max age: 10-1000000 seconds. Default = 300.

## Appendix B

# Cables and Connectors

When connecting the Switch to another switch, a bridge or hub, a normal cable is necessary. Please review these products for matching cable pin assignment.

The following diagrams and tables show the standard RJ-45 receptacle/connector and their pin assignments.

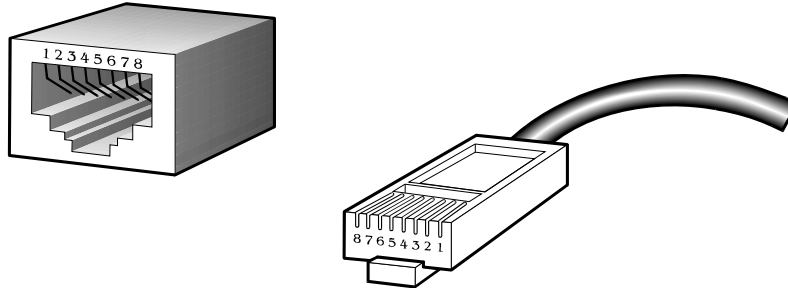

**Figure B- 1. The standard RJ-45 port and connector**

RJ-45 Pin Assignments		
Contact	MDI-X Port	MDI-II Port
1	RD+ (receive)	TD+ (transmit)
2	RD- (receive)	TD- (transmit)
3	TD+ (transmit)	RD+ (receive)
4	1000BASE-T	1000BASE-T
5	1000BASE-T	1000BASE-T
6	TD- (transmit)	RD- (receive)
7	1000BASE-T	1000BASE-T
8	1000BASE-T	1000BASE-T

**Table B- 1. The standard RJ-45 pin assignments**

## Appendix C

# Cable Lengths

Use the following table to as a guide for the maximum cable lengths.

Standard	Media Type	Maximum Distance
Mini-GBIC	1000BASE-LX, Single-mode fiber module	10km
	1000BASE-SX, Multi-mode fiber module	550m / 2km
	1000BASE-LHX, Single-mode fiber module	40km
	1000BASE-ZX, Single-mode fiber module	80km
1000BASE-T	Category 5e UTP Cable	100m
	Category 5 UTP Cable (1000 Mbps)	
100BASE-TX	Category 5 UTP Cable (100 Mbps)	100m
10BASE-T	Category 3 UTP Cable (10 Mbps)	100m

# Glossary

**1000BASE-SX:** A short laser wavelength on multimode fiber optic cable for a maximum length of 550 meters

**1000BASE-LX:** A long wavelength for a "long haul" fiber optic cable for a maximum length of 10 kilometers

**100BASE-FX:** 100Mbps Ethernet implementation over fiber.

**100BASE-TX:** 100Mbps Ethernet implementation over Category 5 and Type 1 Twisted Pair cabling.

**10BASE-T:** The IEEE 802.3 specification for Ethernet over Unshielded Twisted Pair (UTP) cabling.

**ageing:** The automatic removal of dynamic entries from the Switch Database which have timed-out and are no longer valid.

**ATM:** Asynchronous Transfer Mode. A connection oriented transmission protocol based on fixed length cells (packets). ATM is designed to carry a complete range of user traffic, including voice, data and video signals.

**auto-negotiation:** A feature on a port which allows it to advertise its capabilities for speed, duplex and flow control. When connected to an end station that also supports auto-negotiation, the link can self-detect its optimum operating setup.

**backbone port:** A port which does not learn device addresses, and which receives all frames with an unknown address. Backbone ports are normally used to connect the Switch to the backbone of your network. Note that backbone ports were formerly known as designated downlink ports.

**backbone:** The part of a network used as the primary path for transporting traffic between network segments.

**bandwidth:** Information capacity, measured in bits per second, that a channel can transmit. The bandwidth of Ethernet is 10Mbps, the bandwidth of Fast Ethernet is 100Mbps.

**baud rate:** The switching speed of a line. Also known as line speed between network segments.

**BOOTP:** The BOOTP protocol allows automatic mapping of an IP address to a given MAC address each time a device is started. In addition, the protocol can assign the subnet mask and default gateway to a device.

**bridge:** A device that interconnects local or remote networks no matter what higher level protocols are involved. Bridges form a single logical network, centralizing network administration.

**broadcast:** A message sent to all destination devices on the network.

**broadcast storm:** Multiple simultaneous broadcasts that typically absorb available network bandwidth and can cause network failure.

**console port:** The port on the Switch accepting a terminal or modem connector. It changes the parallel arrangement of data within computers to the serial form used on data transmission links. This port is most often used for dedicated local management.

**CSMA/CD:** Channel access method used by Ethernet and IEEE 802.3 standards in which devices transmit only after finding the data channel clear for some period of time. When two devices transmit simultaneously, a collision occurs and the colliding devices delay their retransmissions for a random amount of time.

**data center switching:** The point of aggregation within a corporate network where a switch provides high-performance access to server farms, a high-speed backbone connection and a control point for network management and security.

**Ethernet:** A LAN specification developed jointly by Xerox, Intel and Digital Equipment Corporation. Ethernet networks operate at 10Mbps using CSMA/CD to run over cabling.

**Fast Ethernet:** 100Mbps technology based on the CSMA/CD network access method.

**Flow Control:** (IEEE 802.3X) A means of holding packets back at the transmit port of the connected end station. Prevents packet loss at a congested switch port.

**forwarding:** The process of sending a packet toward its destination by an internetworking device.

**full duplex:** A system that allows packets to be transmitted and received at the same time and, in effect, doubles the potential throughput of a link.

**half duplex:** A system that allows packets to be transmitted and received, but not at the same time. Contrast with full duplex.

**IP address:** Internet Protocol address. A unique identifier for a device attached to a network using TCP/IP. The address is written as four octets separated with full-stops (periods), and is made up of a network section, an optional subnet section and a host section.

**IPX:** Internetwork Packet Exchange. A protocol allowing communication in a NetWare network.

**LAN - Local Area Network:** A network of connected computing resources (such as PCs, printers, servers) covering a relatively small geographic area (usually not larger than a floor or building). Characterized by high data rates and low error rates.

**latency:** The delay between the time a device receives a packet and the time the packet is forwarded out of the destination port.

**line speed:** See baud rate.

**main port:** The port in a resilient link that carries data traffic in normal operating conditions.

**MDI - Medium Dependent Interface:** An Ethernet port connection where the transmitter of one device is connected to the receiver of another device.

**MDI-X - Medium Dependent Interface Cross-over:** An Ethernet port connection where the internal transmit and receive lines are crossed.

**MIB - Management Information Base:** Stores a device's management characteristics and parameters. MIBs are used by the Simple Network Management Protocol (SNMP) to contain attributes of their managed systems. The Switch contains its own internal MIB.

**multicast:** Single packets copied to a specific subset of network addresses. These addresses are specified in the destination-address field of the packet.

**protocol:** A set of rules for communication between devices on a network. The rules dictate format, timing, sequencing and error control.

**resilient link:** A pair of ports that can be configured so that one will take over data transmission should the other fail. See also main port and standby port.

**RJ-45:** Standard 8-wire connectors for IEEE 802.3 10BASE-T networks.

**RMON:** Remote Monitoring. A subset of SNMP MIB II that allows monitoring and management capabilities by addressing up to ten different groups of information.

**RPS - Redundant Power System:** A device that provides a backup source of power when connected to the Switch.

**server farm:** A cluster of servers in a centralized location serving a large user population.

**SLIP - Serial Line Internet Protocol:** A protocol which allows IP to run over a serial line connection.

**SNMP - Simple Network Management Protocol:** A protocol originally designed to be used in managing TCP/IP internets. SNMP is presently implemented on a wide range of computers and networking equipment and may be used to manage many aspects of network and end station operation.

**Spanning Tree Protocol (STP):** A bridge-based system for providing fault tolerance on networks. STP works by allowing the user to implement parallel paths for network traffic, and ensure that redundant paths are disabled when the main paths are operational and enabled if the main paths fail.

**STACK:** A group of network devices that are integrated to form a single logical device.

**standby port:** The port in a resilient link that will take over data transmission if the main port in the link fails.

**switch:** A device which filters, forwards and floods packets based on the packet's destination address. The switch learns the addresses associated with each switch port and builds tables based on this information to be used for the switching decision.

**TCP/IP:** A layered set of communications protocols providing Telnet terminal emulation, FTP file transfer, and other services for communication among a wide range of computer equipment.

**telnet:** A TCP/IP application protocol that provides virtual terminal service, letting a user log in to another computer system and access a host as if the user were connected directly to the host.

**TFTP - Trivial File Transfer Protocol:** Allows the user to transfer files (such as software upgrades) from a remote device using your switch's local management capabilities.

**UDP - User Datagram Protocol:** An Internet standard protocol that allows an application program on one device to send a datagram to an application program on another device.

**VLAN - Virtual LAN:** A group of location- and topology-independent devices that communicate as if they are on a common physical LAN.

**VLT - Virtual LAN Trunk:** A Switch-to-Switch link which carries traffic for all the VLANs on each Switch.

**VT100:** A type of terminal that uses ASCII characters. VT100 screens have a text-based appearance.



Subject to the terms and conditions set forth herein, D-Link Systems, Inc. ("D-Link") provides this lifetime product warranty for hardware:

- Only for products purchased, delivered and used within the fifty states of the United States, the District of Columbia, U.S. Possessions or Protectorates, U.S. Military Installations, or addresses with an APO or FPO, and;
- Only with proof of purchase.

**Product Warranty:** D-Link warrants that the hardware portion of the D-Link product, including internal and external power supplies and fans ("Hardware"), will be free from material defects in workmanship and materials under normal use from the date of original retail purchase of the product ("Warranty Period"), except as otherwise stated herein.

The customer's sole and exclusive remedy and the entire liability of D-Link and its suppliers under this Warranty will be, at D-Link's option, to repair or replace the defective Hardware during the Warranty Period at no charge to the owner or to refund the actual purchase price paid. Any repair or replacement will be rendered by D-Link at an Authorized D-Link Service Office. The replacement hardware need not be new or have an identical make, model or part. D-Link may, at its option, replace the defective Hardware or any part thereof with any reconditioned product that D-Link reasonably determines is substantially equivalent (or superior) in all material respects to the defective Hardware. Repaired or replacement hardware will be warranted for the remainder of the original Warranty Period or ninety (90) days, whichever is longer, and is subject to the same limitations and exclusions. If a material defect is incapable of correction, or if D-Link determines that it is not practical to repair or replace the defective Hardware, the actual price paid by the original purchaser for the defective Hardware will be refunded by D-Link upon return to D-Link of the defective Hardware. All Hardware or part thereof that is replaced by D-Link, or for which the purchase price is refunded, shall become the property of D-Link upon replacement or refund.

**Software Warranty:** D-Link warrants that the software portion of the product ("Software") will substantially conform to D-Link's then current functional specifications for the Software, as set forth in the applicable documentation, from the date of original retail purchase of the Software for a period of ninety (90) days ("Software Warranty Period"), provided that the Software is properly installed on approved hardware and operated as contemplated in its documentation. D-Link further warrants that, during the Software Warranty Period, the magnetic media on which D-Link delivers the Software will be free of physical defects. The customer's sole and exclusive remedy and the entire liability of D-Link and its suppliers under this Limited Warranty will be, at D-Link's option, to replace the non-conforming Software (or defective media) with software that substantially conforms to D-Link's functional specifications for the Software or to refund the portion of the actual purchase price paid that is attributable to the Software. Except as otherwise agreed by D-Link in writing, the replacement Software is provided only to the original licensee, and is subject to the terms and conditions of the license granted by D-Link for the Software. Replacement Software will be warranted for the remainder of the original Warranty Period and is subject to the same limitations and exclusions. If a material non-conformance is incapable of correction, or if D-Link determines in its sole discretion that it is not practical to replace the non-conforming Software, the price paid by the original licensee for the non-conforming Software will be refunded by D-Link; provided that the non-conforming Software (and all copies thereof) is first returned to D-Link. The license granted respecting any Software for which a refund is given automatically terminates.

**Non-Applicability of Warranty:** The Warranty provided hereunder for D-Link's products will not be applied to and does not cover any products obtained through a special or unique pricing agreement, if such agreement provides for warranty terms different from those normally provided with the product or set forth herein, nor to any refurbished product and any product purchased through the inventory clearance or liquidation sale or other sales in which D-Link, the sellers, or the liquidators expressly disclaim their warranty obligation pertaining to the product and in that case, the product is being sold "As-Is" without any warranty whatsoever including, without limitation, the Warranty as described herein, notwithstanding anything stated herein to the contrary.

**Submitting A Claim:** The customer shall return the product to the original purchase point based on its return policy. In case the return policy period has expired and the product is within warranty, the customer shall submit a claim to D-Link as outlined below:

- The customer must submit with the product as part of the claim a written description of the Hardware defect or Software nonconformance in sufficient detail to allow D-Link to confirm the same, along with proof of purchase of the product (such as a copy of the dated purchase invoice for the product).
- The customer must obtain a Case ID Number from D-Link Technical Support by going to <https://support.dlink.com>, who will attempt to assist the customer in resolving any suspected defects with the product. If the product is considered defective, the customer must obtain a Return Material Authorization ("RMA") number by completing the RMA form and entering the assigned Case ID Number at <https://rma.dlink.com/>.
- After an RMA number is issued, the defective product must be packaged securely in the original or other suitable shipping package to ensure that it will not be damaged in transit, and the RMA number must be prominently marked on the outside of the package. Include any manuals or accessories in the shipping package.
- The customer is responsible for all in-bound shipping charges to D-Link. No Cash on Delivery ("COD") is allowed. Products sent COD will either be rejected by D-Link or become the property of D-Link. Products shall be fully insured by the customer and shipped to **D-Link Systems, Inc., 17595 Mt. Herrmann, Fountain Valley, CA 92708**. D-Link will not be held responsible for any packages that are lost in transit to D-Link. The repaired or replaced packages will be shipped to the customer via UPS Ground or any common carrier selected by D-Link. Return shipping charges shall be prepaid by D-Link if you use an address in the United States, otherwise we will ship the product to you freight collect. Expedited shipping is available upon request and provided shipping charges are prepaid by the customer.

D-Link may reject or return any product that is not packaged and shipped in strict compliance with the foregoing requirements, or for which an RMA number is not visible from the outside of the package. The product owner agrees to pay D-Link's reasonable handling and return shipping charges for any product that is not packaged and shipped in accordance with the foregoing requirements, or that is determined by D-Link not to be defective or non-conforming.

**What Is Not Covered:** The Warranty provided herein by D-Link does not cover: Products that, in D-Link's judgment, have been subjected to abuse, accident, alteration, modification, tampering, negligence, misuse, faulty installation, lack of reasonable care, repair or service in any way that is not contemplated in the documentation for the product, or if the model or serial number has been altered, tampered with, defaced or removed; Initial installation, installation and removal of the product for repair, and shipping costs; Operational adjustments covered in the operating manual for the product, and normal maintenance; Damage that occurs in shipment, due to act of God, failures due to power surge, and cosmetic damage; Any hardware, software, firmware or other products or services provided by anyone other than D-Link; and Products that have been purchased from inventory clearance or liquidation sales or other sales in which D-Link, the sellers, or the liquidators expressly disclaim their warranty obligation pertaining to the product. While necessary maintenance or repairs on your Product can be performed by any company, we recommend that you use only an Authorized D-Link Service Office. Improper or incorrectly performed maintenance or repair voids this Warranty.

**Disclaimer of Other Warranties:** EXCEPT AS SPECIFICALLY SET FORTH ABOVE OR AS REQUIRED BY LAW, THE PRODUCT IS PROVIDED "AS-IS" WITHOUT ANY WARRANTY OF ANY KIND WHATSOEVER INCLUDING, WITHOUT LIMITATION, ANY WARRANTY OF MERCHANTABILITY, FITNESS FOR A PARTICULAR PURPOSE AND NON-INFRINGEMENT. IF ANY IMPLIED WARRANTY CANNOT BE DISCLAIMED IN ANY TERRITORY WHERE A PRODUCT IS SOLD, THE DURATION OF SUCH IMPLIED WARRANTY SHALL BE LIMITED TO NINETY (90) DAYS. EXCEPT AS EXPRESSLY COVERED UNDER THE WARRANTY PROVIDED HEREIN, THE ENTIRE RISK AS TO THE QUALITY, SELECTION AND PERFORMANCE OF THE PRODUCT IS WITH THE PURCHASER OF THE PRODUCT.

**Limitation of Liability:** TO THE MAXIMUM EXTENT PERMITTED BY LAW, D-LINK IS NOT LIABLE UNDER ANY CONTRACT, NEGLIGENCE, STRICT LIABILITY OR OTHER LEGAL OR EQUITABLE THEORY FOR ANY LOSS OF USE OF THE PRODUCT, INCONVENIENCE OR DAMAGES OF ANY CHARACTER, WHETHER DIRECT, SPECIAL, INCIDENTAL OR CONSEQUENTIAL (INCLUDING, BUT NOT LIMITED TO, DAMAGES FOR LOSS OF GOODWILL, LOSS OF REVENUE OR PROFIT, WORK STOPPAGE, COMPUTER FAILURE OR MALFUNCTION, FAILURE OF OTHER EQUIPMENT OR COMPUTER PROGRAMS TO WHICH D-LINK'S PRODUCT IS CONNECTED WITH, LOSS OF INFORMATION OR DATA CONTAINED IN, STORED ON, OR INTEGRATED WITH ANY PRODUCT RETURNED TO D-LINK FOR WARRANTY SERVICE) RESULTING FROM THE USE OF THE PRODUCT, RELATING TO WARRANTY SERVICE, OR ARISING OUT OF ANY BREACH OF THIS WARRANTY, EVEN IF D-LINK HAS BEEN ADVISED OF THE POSSIBILITY OF SUCH DAMAGES. THE SOLE REMEDY FOR A BREACH OF THE FOREGOING WARRANTY IS REPAIR, REPLACEMENT OR REFUND OF THE DEFECTIVE OR NON-CONFORMING PRODUCT. THE MAXIMUM LIABILITY OF D-LINK UNDER THIS WARRANTY IS LIMITED TO THE PURCHASE PRICE OF THE PRODUCT COVERED BY THE WARRANTY. THE FOREGOING EXPRESS WRITTEN WARRANTIES AND REMEDIES ARE EXCLUSIVE AND ARE IN LIEU OF ANY OTHER WARRANTIES OR REMEDIES, EXPRESS, IMPLIED OR STATUTORY.

**Lifetime Warranty:** IF LOCAL LAW MANDATES THE USE OF A DEFINITION OF "LIFETIME WARRANTY" DIFFERENT FROM THAT PROVIDED HEREIN, THEN THE LOCAL LAW DEFINITION WILL SUPERSEDE AND TAKE PRECEDENCE, TO THE EXTENT NECESSARY TO COMPLY.

**Governing Law:** This Warranty shall be governed by the laws of the State of California. Some states do not allow exclusion or limitation of incidental or consequential damages, or limitations on how long an implied warranty lasts, so the foregoing limitations and exclusions may not apply. This Warranty provides specific legal rights and you may also have other rights which vary from state to state.

**Trademarks:** D-Link is a registered trademark of D-Link Systems, Inc. Other trademarks or registered trademarks are the property of their respective owners.

**Copyright Statement:** No part of this publication or documentation accompanying this product may be reproduced in any form or by any means or used to make any derivative such as translation, transformation, or adaptation without permission from D-Link Corporation/D-Link Systems, Inc., as stipulated by the United States Copyright Act of 1976 and any amendments thereto. Contents are subject to change without prior notice. Copyright 2009 by D-Link Corporation/D-Link Systems, Inc. All rights reserved.

**CE Mark Warning:** This is a Class A product. In a residential environment, this product may cause radio interference, in which case the user may be required to take adequate measures.

**FCC Statement:** This equipment has been tested and found to comply with the limits for a Class A digital device, pursuant to part 15 of the FCC Rules. These limits are designed to provide reasonable protection against harmful interference in a commercial installation. This equipment generates, uses, and can radiate radio frequency energy and, if not installed and used in accordance with the instructions, may cause harmful interference to radio communication. However, there is no guarantee that interference will not occur in a particular installation. Operation of this equipment in a residential environment is likely to cause harmful interference to radio or television reception. If this equipment does cause harmful interference to radio or television reception, which can be determined by turning the equipment off and on, the user is encouraged to try to correct the interference by one or more of the following measures:

- Reorient or relocate the receiving antenna.
- Increase the separation between the equipment and receiver.
- Connect the equipment into an outlet on a circuit different from that to which the receiver is connected.
- Consult the dealer or an experienced radio/TV technician for help.

**For detailed warranty information applicable to products purchased outside the United States, please contact the corresponding local D-Link office.**

## *Product Registration*

*Register your D-Link product online at <http://support.dlink.com/register/>  
Product registration is entirely voluntary and failure to complete or return this form will not diminish your warranty rights.*

# Tech Support

## Technical Support

You can find software updates and user documentation on the D-Link website.

D-Link provides free technical support for customers within the United States and within Canada for the duration of the service period, and warranty confirmation service, during the warranty period on this product. U.S. and Canadian customers can contact D-Link technical support through our website, or by phone.

### Tech Support for customers within the United States:

***D-Link Technical Support over the Telephone:***

USA - 877-DLINK-55 (877-354-6555)

***D-Link Technical Support over the Internet:***

<http://support.dlink.com>

### Tech Support for customers within Canada:

***D-Link Technical Support over the Telephone:***

877-354-6560

***D-Link Technical Support over the Internet:***

<http://support.dlink.com>

**D-Link<sup>®</sup>**  
Building Networks for People

## Technical Support

### United Kingdom (Mon-Fri)

Home Wireless/Broadband 0871 873 3000 (9.00am–06.00pm, Sat 10.00am-02.00pm)  
Managed, Smart, & Wireless Switches, or Firewalls 0871 873 0909 (09.00am – 05.30pm)  
(BT 10ppm, other carriers may vary.)

### Ireland (Mon-Fri)

All Products 1890 886 899 (09.00am-06.00pm, Sat 10.00am-02.00pm)  
€ 0.05ppm peak, €0.045ppm off peak Times

### Internet

<http://www.dlink.co.uk>

<ftp://ftp.dlink.co.uk>

## Technische Unterstützung

Deutschland:	Web:	<a href="http://www.dlink.de">http://www.dlink.de</a>
	Telefon:	+49(0)1805 2787 0,14 € pro Minute
	Zeiten:	Mo. –Fr. 08:30 – 17:30 Uhr
Österreich:	Web:	<a href="http://www.dlink.at">http://www.dlink.at</a>
	Telefon:	+43(0)820 480084 0,116 € pro Minute
	Zeiten:	Mo. –Fr. 08:30 – 17:30 Uhr
Schweiz:	Web:	<a href="http://www.dlink.ch">http://www.dlink.ch</a>
	Telefon:	+41(0)848 331100 0,08 CHF pro Minute
	Zeiten:	Mo. –Fr. 08:30 – 17:30 Uhr

\* Gebühren aus Mobilnetzen und von anderen Providern können abweichen.

## Assistance technique

Assistance technique D-Link sur internet : <http://www.dlink.fr>

Assistance technique D-Link par téléphone : 0820 0803 03

0.12 € TTC/min depuis un poste fixe

Du lundi au vendredi de 9h à 19h (hors jours fériés)

## Asistencia Técnica

Asistencia Técnica Telefónica de D-Link: +34 902 30 45 45

0,067 €/min

De Lunes a Viernes de 9:00 a 19:00

<http://www.dlink.es>

## Supporto tecnico

Supporto Tecnico dal lunedì al venerdì dalle ore 9.00 alle ore 19.00 con orario continuato

Telefono: 199400057

<http://www.dlink.it/support>

## TECHNISCHE ONDERSTEUNING

Technische ondersteuning voor klanten in Nederland:

[www.dlink.nl](http://www.dlink.nl) / 0900 501 2007 / €0.15per minuut.

Tech Support for customers within Belgium:

[www.dlink.be](http://www.dlink.be) / 070 66 06 40 / €0.175per minuut(spitsuren), €0.0875per minuut(daluren)

Technische ondersteuning voor klanten in Luxemburg:

[www.dlink.be](http://www.dlink.be) / +32 70 66 06 40

## Pomoc techniczna

Telefoniczna pomoc techniczna firmy D-Link: 0 801 022 021

Pomoc techniczna firmy D-Link świadczona przez Internet:

<http://www.dlink.eu/support/>

## Technická podpora

Web: <http://www.dlink.cz/support/>

E-mail: [support@dlink.cz](mailto:support@dlink.cz)

Telefon: 225 281 553

Telefonická podpora je v provozu: PO – PÁ od 08:00 do 17:00

Pevná linka 1,78 Kč/min. –mobil 5,40 Kč/min.

## Technikai Támogatás

Tel. : 06 1 461-3001

Fax : 06 1 461-3004

Land Line 14,99 HUG/min - Mobile 49.99,HUF/min

email : [support@dlink.hu](mailto:support@dlink.hu)

URL : <http://www.dlink.hu>

## Teknisk Support

D-Link Teknisk telefon Support: 820 00 755

(Hverdager 08:00-20:00)

D-Link Teknisk Support over Internett: <http://www.dlink.no>

## Teknisk Support

D-Link teknisk support over telefonen: Tlf.: 9013 8899

Normale åbningstider: Hverdage kl. 08:00 - 20:00

D-Link teknisk support på Internettet: <http://www.dlink.dk>

## **Teknistä tukea asiakkaille Suomessa:**

Arkisin klo. 9 - 21  
numerosta : **06001 5557**  
Internetin kautta : <http://www.dlink.fi>

## **Teknisk Support**

D-Link Teknisk Support via telefon: 0900-100 77 00  
Vardagar 08.00-20.00  
D-Link Teknisk Support via Internet: <http://www.dlink.se>

## **Assistência Técnica**

Assistência Técnica da D-Link na Internet:  
<http://www.dlink.pt>  
e-mail: [soporte@dlink.es](mailto:soporte@dlink.es)

## **Τεχνική Υποστήριξη**

D-Link Hellas Support Center  
Κεφαλληνίας 64, 11251 Αθήνα,  
Τηλ: 210 86 11 114 (Δευτέρα- Παρασκευή 09:00-17:00)  
Φαξ: 210 8611114  
<http://www.dlink.gr/support>



## **Tehnička podrška**

Hvala vam na odabiru D-Link proizvoda. Za dodatne informacije, podršku i upute za korištenje uređaja, molimo vas da posjetite D-Link internetsku stranicu na [www.dlink.eu](http://www.dlink.eu)  
[www.dlink.biz/hr](http://www.dlink.biz/hr)

## **Tehnična podpora**

Zahvaljujemo se vam, ker ste izbrali D-Link proizvod. Za vse nadaljnje informacije, podporo ter navodila za uporabo prosimo obiščite D-Link - ovo spletno stran [www.dlink.eu](http://www.dlink.eu)  
[www.dlink.biz/sl](http://www.dlink.biz/sl)

## **Suport tehnic**

Vă mulțumim pentru alegerea produselor D-Link. Pentru mai multe informații, suport și manuale ale produselor vă rugăm să vizitați site-ul D-Link [www.dlink.eu](http://www.dlink.eu)  
[www.dlink.ro](http://www.dlink.ro)

## Technical Support

You can find software updates and user documentation on the D-Link website.

### Tech Support for customers in

#### Australia:

Tel: 1300-766-868

24/7 Technical Support

Web: <http://www.dlink.com.au>

E-mail: [support@dlink.com.au](mailto:support@dlink.com.au)

#### India:

Tel: 1800-233-0000 (MTNL & BSNL Toll Free)

+91-832-2885700 (GSM, CDMA & Others)

Web: [www.dlink.co.in](http://www.dlink.co.in)

E-Mail: [helpdesk@dlink.co.in](mailto:helpdesk@dlink.co.in)

### Indonesia, Malaysia, Singapore and Thailand:

Tel: +62-21-5731610 (Indonesia)

Tel: 1800-882-880 (Malaysia)

Tel: +65 6501 4200 (Singapore)

Tel: +66-2-719-8978/9 (Thailand)

24/7, for English Support only

Web: <http://www.dlink.com.sg/support/>

E-mail: [support@dlink.com.sg](mailto:support@dlink.com.sg)

#### Korea:

Tel: +82-2-2028-1815

Monday to Friday 9:00am to 6:00pm

Web: <http://www.d-link.co.kr>

E-mail: [arthur@d-link.co.kr](mailto:arthur@d-link.co.kr)

#### New Zealand:

Tel: 0800-900-900

24/7 Technical Support

Web: <http://www.dlink.co.nz>

E-mail: [support@dlink.co.nz](mailto:support@dlink.co.nz)

**D-Link®**  
Building Networks for People

## Technical Support

You can find software updates and user documentation on the D-Link website.  
*Tech Support for customers in*

### **Egypt:**

Tel: +202-2919035, +202-2919047  
Sunday to Thursday 9:00am to 5:00pm  
Web: <http://support.dlink-me.com>  
E-mail: [support.eg@dlink-me.com](mailto:support.eg@dlink-me.com)

### **Iran:**

Tel: +98-21-88880918,19  
Saturday to Thursday 9:00am to 5:00pm  
Web: <http://support.dlink-me.com>  
E-mail: [support.ir@dlink-me.com](mailto:support.ir@dlink-me.com)  
[support@dlink.ir](mailto:support@dlink.ir)

### **Israel:**

Magshimim 20, Petach Tikva 49348  
Main Tel: 972-3-9215173  
Customer Support Tel: 972-3-9212886  
Web: [www.dlink.co.il](http://www.dlink.co.il)

### **Pakistan:**

Tel: +92-21-4548158  
+92-21-4548310  
Monday to Friday 10:00am to 6:00pm  
Web: <http://support.dlink-me.com>  
E-mail: [zkashif@dlink-me.com](mailto:zkashif@dlink-me.com)

### **South Africa and Sub Sahara Region:**

Tel: +27-12-665-2165  
08600 DLINK (for South Africa only)  
Monday to Friday 8:30am to 9:00pm South Africa Time  
Web: <http://www.d-link.co.za>  
E-mail: [support@d-link.co.za](mailto:support@d-link.co.za)

### **Turkey:**

Tel: +90-212-2895659  
Monday to Friday 9:00am to 6:00pm  
Web: <http://www.dlink.com.tr>  
E-mail: [turkiye@dlink-me.com](mailto:turkiye@dlink-me.com)

### **U.A.E and North Africa:**

Tel: +971-4-4278127 (U.A.E)  
Sunday to Thursday 9.00AM to 6.00PM GMT+4  
Web: <http://www.dlink-me.com>  
E-mail: [support.me@dlink-me.com](mailto:support.me@dlink-me.com)

### **Saudi ARABIA (KSA):**

Tel: +966 01 217 0008  
Fax: +966 01 217 0009  
Saturday to Wednesday 9.30AM to 6.30PM  
Thursdays 9.30AM to 2.00 PM  
E-mail: [Support.sa@dlink-me.com](mailto:Support.sa@dlink-me.com)

**D-Link®**  
Building Networks for People

## Техническая поддержка

Обновления программного обеспечения и документация доступны на Интернет-сайте D-Link.

D-Link предоставляет бесплатную поддержку для клиентов в течение гарантийного срока.

Клиенты могут обратиться в группу технической поддержки D-Link по телефону или через Интернет.

### **Техническая поддержка D-Link:**

+7(495) 744-00-99

### **Техническая поддержка через Интернет**

<http://www.dlink.ru>

e-mail: [support@dlink.ru](mailto:support@dlink.ru)

**D-Link®**  
Building Networks for People

## SOPORTE TÉCNICO

Usted puede encontrar actualizaciones de softwares o firmwares y documentación para usuarios a través de nuestro sitio [www.dlinkla.com](http://www.dlinkla.com)

### SOPORTE TÉCNICO PARA USUARIOS EN LATINO AMERICA

Soporte técnico a través de los siguientes teléfonos de D-Link

PAIS	NUMERO
Argentina	0800 - 12235465
Chile	800 - 835465 ó (02) 5941520
Colombia	01800 - 9525465
Costa Rica	0800 - 0521478
Ecuador	1800 - 035465
El Salvador	800 - 6335
Guatemala	1800 - 8350255
México	01800 - 1233201
Panamá	011 008000525465
Perú	0800 - 00968
Venezuela	0800 - 1005767

### Soporte Técnico de D-Link a través de Internet

Horario de atención Soporte Técnico en [www.dlinkla.com](http://www.dlinkla.com)

e-mail: [soporte@dlinkla.com](mailto:soporte@dlinkla.com) & [consultas@dlinkla.com](mailto:consultas@dlinkla.com)

**D-Link**<sup>®</sup>  
Building Networks for People

## Suporte Técnico

Você pode encontrar atualizações de software e documentação de usuário no site da D-Link Brasil.

A D-Link fornece suporte técnico gratuito para clientes no Brasil durante o período de vigência da garantia deste produto.

### **Suporte Técnico para clientes no Brasil:**

Website para suporte: [www.dlink.com.br/suporte](http://www.dlink.com.br/suporte)  
e-mail: [suporte@dlink.com.br](mailto:suporte@dlink.com.br)

### **Telefones para contato:**

Clientes de São Paulo: 2755 6950  
Clientes das demais regiões: 0800 70 24 104  
Segunda à Sexta-feira, das 9:00h às 21:00h  
Sábado, das 9:00h às 15:00h

**D-Link**<sup>®</sup>  
Building Networks for People

## D-Link 友訊科技 台灣分公司 技術支援資訊

如果您還有任何本使用手冊無法協助您解決的產品相關問題，台灣地區用戶可以透過我們的網站、電子郵件或電話等方式與D-Link台灣地區技術支援工程師聯絡。

**D-Link 免付費技術諮詢專線**

0800-002-615

服務時間：週一至週五，早上9:00到晚上9:00

(不含周六、日及國定假日)

網 站：<http://www.dlink.com.tw>

電子郵件：[dssqa\\_service@dlink.com.tw](mailto:dssqa_service@dlink.com.tw)

如果您是台灣地區以外的用戶，請參考D-Link網站全球各地分公司的聯絡資訊以取得相關支援服務。

產品保固期限、台灣區維修據點查詢，請參考以下網頁說明：

<http://www.dlink.com.tw>

產品維修：

使用者可直接送至全省聯強直營維修站或請洽您的原購買經銷商。

**D-Link<sup>®</sup>**  
Building Networks for People

## **Dukungan Teknis**

Update perangkat lunak dan dokumentasi pengguna dapat diperoleh pada situs web D-Link.

### **Dukungan Teknis untuk pelanggan:**

#### **Dukungan Teknis D-Link melalui telepon:**

Tel: +62-21-5731610

#### **Dukungan Teknis D-Link melalui Internet:**

Email : [support@dlink.co.id](mailto:support@dlink.co.id)

Website : <http://support.dlink.co.id>

**D-Link<sup>®</sup>**  
Building Networks for People



## Technical Support

この度は弊社製品をお買い上げいただき、誠にありがとうございます。  
ございます。

下記弊社 Web サイトからユーザ登録及び新製品登録を  
行っていただくと、ダウンロードサービスにて  
サポート情報、ファームウェア、ユーザマニュアルを  
ダウンロードすることができます。

ディーリンクジャパン Web サイト

URL:<http://www.dlink-jp.com>

**D-Link**<sup>®</sup>  
Building Networks for People

## 技术支持

办公地址：北京市东城区北三环东路 36 号 环球贸易中心 B 座  
26F 02-05 室 邮编: 100013

技术支持中心电话：8008296688/ (028)66052968

技术支持中心传真：(028)85176948

各地维修中心地址请登陆官方网站查询

网址：<http://www.dlink.com.cn>

办公时间：周一到周五，早09:00到晚18:00

**D-Link**<sup>®</sup>  
Building Networks for People

# Registration Card

## All Countries and Regions Excluding USA

*Print, type or use block letters.*

Your name: Mr./Ms \_\_\_\_\_

Organization: \_\_\_\_\_ Dept. \_\_\_\_\_

Your title at organization: \_\_\_\_\_

Telephone: \_\_\_\_\_ Fax: \_\_\_\_\_

Organization's full address: \_\_\_\_\_

Country: \_\_\_\_\_

Date of purchase (Month/Day/Year): \_\_\_\_\_

Product Model	Product Serial No.	* Product installed in type of computer	* Product installed in computer serial No.

(\* Applies to adapters only)

*Product was purchased from:*

Reseller's name: \_\_\_\_\_

Telephone: \_\_\_\_\_

**Answers to the following questions help us to support your product:**

**1. Where and how will the product primarily be used?**

Home Office Travel Company Business Home Business Personal Use

**2. How many employees work at installation site?**

1 employee 2-9 10-49 50-99 100-499 500-999 1000 or more

**3. What network protocol(s) does your organization use ?**

XNS/IPX TCP/IP DECnet Others \_\_\_\_\_

**4. What network operating system(s) does your organization use ?**

D-Link LANsmart Novell NetWare NetWare Lite SCO Unix/Xenix PC NFS 3Com 3+Open Cisco Network  
Banyan Vines DECnet Pathwork Windows NT Windows 98 Windows 2000/ME Windows XP  
Others \_\_\_\_\_

**5. What network management program does your organization use ?**

D-View HP OpenView/Windows HP OpenView/Unix SunNet Manager Novell NMS  
NetView 6000 Others \_\_\_\_\_

**6. What network medium/media does your organization use ?**

Fiber-optics Thick coax Ethernet Thin coax Ethernet 10BASE-T UTP/STP  
100BASE-TX 1000BASE-T Wireless 802.11b and 802.11g wireless 802.11a Others \_\_\_\_\_

**7. What applications are used on your network?**

Desktop publishing Spreadsheet Word processing CAD/CAM  
Database management Accounting Others \_\_\_\_\_

**8. What category best describes your company?**

Aerospace Engineering Education Finance Hospital Legal Insurance/Real Estate Manufacturing  
Retail/Chain store/Wholesale Government Transportation/Utilities/Communication VAR  
System house/company Other \_\_\_\_\_

**9. Would you recommend your D-Link product to a friend?**

Yes No Don't know yet

**10. Your comments on this product?**

\_\_\_\_\_

\_\_\_\_\_

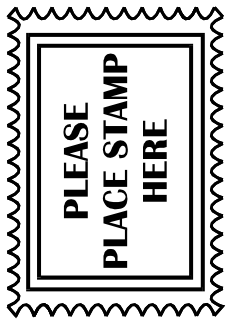

**TO:**

---

---

---

**D-Link®**